



DUPLIX STRAINER ♦ DUAL BALL TYPE ♦ THREE PIECE BODY
ASME CLASS 125 ♦ CAST IRON ♦ FLANGED & THREADED ENDS

NEW
Three-Piece
Design!

MODELS: DS 595-CI
(THREADED - CAST IRON)

DS 695-CI
(FLANGED - CAST IRON)



1 1/2" DS 695-CI

FEATURES

SIZE RANGE: 3/4" ~ 4"

♦ DUAL-BALL DIVERTER DESIGN

THIS DUPLIX IS DESIGNED WITH TWO STAINLESS STEEL BALLS THAT EFFICIENTLY DIVERT THE PIPELINE FLOW FROM ONE BASKET CHAMBER TO THE OTHER. TEFLON SEATS ENSURE A POSITIVE SEAL AND HELP TO PREVENT SEEPAGE INTO THE CHAMBER THAT IS BEING SERVICED FOR CLEANING.

♦ EASY TO OPERATE

THE TITAN[†] FCI DUPLIX STRAINER FEATURES A LOW TORQUE, EASY TO OPERATE HANDLE THAT DOES NOT REQUIRE A GEARBOX. ADDITIONALLY, THE HANDLE'S POSITION CLEARLY INDICATES WHICH BASKET IS IN SERVICE AND WHICH BASKET CAN SAFELY BE REMOVED FOR CLEANING.

♦ REDUCED "IN-LINE" MAINTENANCE

TITAN'S DUPLIX HAS NUMEROUS ATTRIBUTES THAT HELP REDUCE MAINTENANCE DURING CLEANING OPERATIONS. FIRST, THE DUAL BALL DESIGN ISOLATES EACH CHAMBER AND KEEPS THE SERVICING CHAMBER DRY DURING CLEANING. THERE ARE ALSO NO SPECIAL TOOLS REQUIRED TO ACCESS AND REMOVE THE STRAINING ELEMENT FROM THE CHAMBER. LASTLY, THE DUPLIX PROVIDES COVER VENTS, DRAIN PLUGS, AND FOOT PADS ON EACH CHAMBER.

♦ ENDLESS SCREEN OPTIONS

THIS STRAINER CAN BE FITTED WITH VIRTUALLY ANY CONFIGURATION OF PERFORATION OR MESH LINED STRAINING ELEMENTS. STRAINING ELEMENTS CAN ALSO BE CONSTRUCTED FROM SPECIAL MATERIALS SUCH AS ALLOY 20.

TECHNICAL

PRESSURE/ TEMPERATURE RATING ⁽¹⁾
CAST IRON - A126 GR. B - CLASS 125

DS 595-CI (Threaded)
WOG (Non-shock): 200 PSI @ 150 °F

DS 695-CI (Flanged)
WOG (Non-shock): 200 PSI @ 150 °F

1. The above listed temperatures are theoretical and may vary during actual operating conditions.
2. Max and min temperatures are for reference only. Prolonged use at these temperatures is not recommended for optimal service life.

APPLICATIONS

GENERAL APPLICATION: THE DUPLIX STRAINER IS A UNIQUE PRODUCT WITHIN THE PIPELINE INDUSTRY. LIKE OTHER BASKET STRAINERS, THE DUPLIX STRAINER PROTECTS EXPENSIVE DOWNSTREAM EQUIPMENT BY MECHANICALLY REMOVING SOLIDS FROM FLOWING FLUIDS VIA A PERFORATED, MESH, OR WEDGE WIRE STRAINING ELEMENT. HOWEVER, THE DUPLIX STRAINER IS DESIGNED WITH TWO BASKET CHAMBERS AND A FLOW DIVERTER SYSTEM THAT ALLOWS THE PIPELINE FLOW TO BE SWITCHED FROM ONE CHAMBER TO THE OTHER, COMPLETELY ISOLATING THE FLOW TO A SINGLE CHAMBER. THIS MAKES THE DUPLIX STRAINER IDEAL FOR NON-INTERRUPTIBLE APPLICATIONS THAT CANNOT BE SHUT DOWN DURING ROUTINE MAINTENANCE AND CLEANING OPERATIONS.

Ball-Type Duplex Strainers are not recommended for slurry and fibrous content applications.

The above data represents common market and service applications. No representation or guarantee, expressed or implied, is given due to the numerous variations of concentrations, temperatures and flow conditions that may occur during actual service.

TITAN[®] FLOW CONTROL, INC.
YOUR PIPELINE TO THE FUTURE!

Tel: 910-735-0000 ♦ Fax: 910-738-3848 ♦ titan@titanfci.com ♦ www.titanfci.com
290 Corporate Drive ♦ PO Box 7408 ♦ Lumberton, NC 28358



TITAN® FLOW CONTROL, Inc.
 290 Corporate Drive
 Lumberton, NC 28358
 Tel: 910.735.0000
 E-mail: titan@titanfci.com
 Web: www.titanfci.com
 Fax: 910.738.3848

DUPLEX BASKET STRAINER
DS 595-CI (Threaded)
DS 695-CI (Flanged)
 Dual Ball Type • 3-Piece Body • Cast Iron

ASME
 Class
 125

BILL OF MATERIALS (1)

No.	Part	DS 595/695-CI
1	Main Body / Basket Housing (2)	Cast Iron ASTM A126 Gr. B
2	Straining Element (3)	Stainless Steel
3	Cover	Cast Iron ASTM A126 Gr. B
4	Ball	Stainless Steel
5	O-Ring Straining Element	Buna-N
6	Seat	Teflon (PTFE)
7	Seal	Buna-N
8	O-Ring Body	Buna-N
9	Handle	Carbon Steel Zinc Coated

1. Bill of Materials represents standard materials. Equivalent or better materials may be substituted at the manufacturer's discretion.
2. Carbon Steel, Stainless Steel, and Aluminum Bronze units are also available.
3. Denotes recommended spare parts.

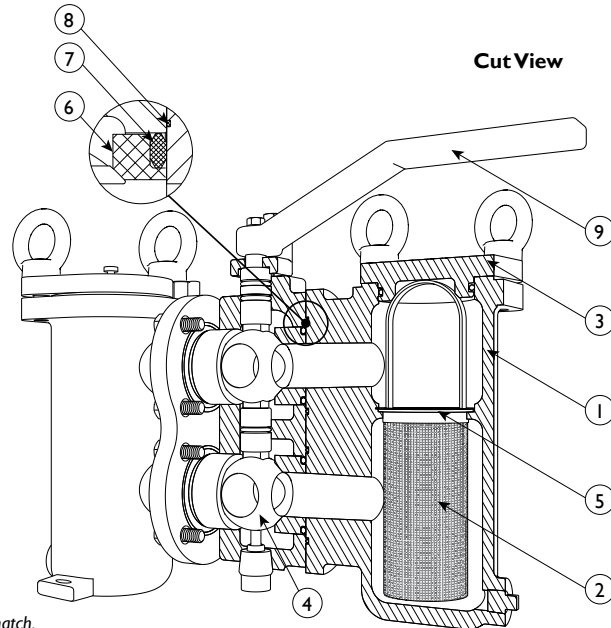

Cut parts shown with hatch.

Illustrations are representative of a 1" DS696-CS (Flanged model). Please ask for certified drawings when required.

Front View

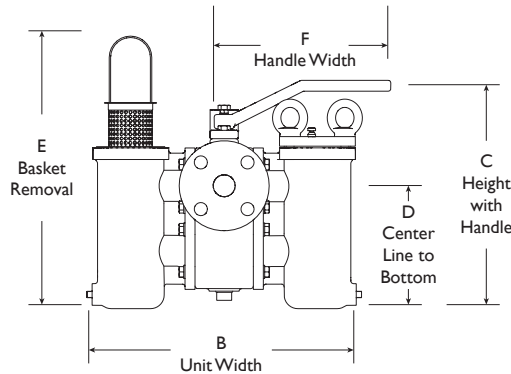

Top View

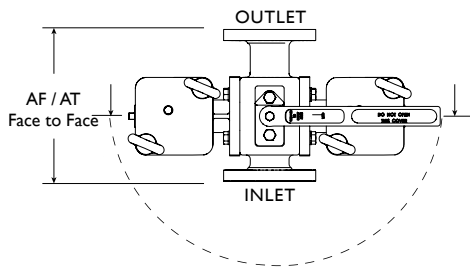

DIMENSIONS AND PERFORMANCE DATA (1)

SIZE (2)									
	in	3/4 (3)	1	1 1/4	1 1/2	2	2 1/2	3 (3)	4 (3)
AF DIMENSION FLANGED FACE TO FACE	in	---	7.0	9.37	9.37	10.6	13.5	13.5	16.0
	mm	---	178	238	238	270	343	343	406
AT DIMENSION THREADED FACE TO FACE	in	5.59	5.59	7.5	7.5	10.0	11.5	---	---
	mm	142	142	191	191	254	292	---	---
B DIMENSION UNIT WIDTH (INCLUDING PLUG)	in	12.95	12.95	15.12	15.12	18.43	22.05	22.0	26.85
	mm	329	329	384	384	468	560	560	682
C DIMENSION HEIGHT WITH HANDLE	in	12.0	12.0	14.8	14.8	18.4	22.7	22.7	25.5
	mm	305	305	377	377	468	579	579	649
D DIMENSION CENTER LINE TO BOTTOM	in	5.83	5.83	8.3	8.3	10.7	13.7	13.7	15.9
	mm	148	148	211	211	271	347	347	403
E DIMENSION BASKET REMOVAL	in	15.4	15.4	21.3	21.3	26.4	35.0	35.0	41.0
	mm	390	390	541	541	670	885	885	1040
F DIMENSION HANDLE LENGTH	in	7.87	7.87	7.87	7.87	10.03	13.00	13.00	15.00
	mm	200	200	200	200	270	330	330	380
APPROXIMATE WEIGHT DS 695, FLANGED	lb	---	46.3	73.9	73.9	121.3	237.0	238.1	373.7
	kg	---	21	33.5	33.5	55	107.5	108	169.5
APPROXIMATE WEIGHT DS 595, THREADED	lb	43.7	43.0	69.9	69.5	119.0	227.0	---	---
	kg	19.8	19.5	31.7	31.5	54	103	---	---
Flow Coefficient	C _v	13	14	19	24	42	68	105	180

1. Dimensions, weights, and flow coefficients are provided for reference only. Always request certified drawings.
2. Larger sizes (5" ~ 8") are available upon request. Please contact factory for pricing and delivery.
3. Flanged units are not available in 3/4" size; Threaded units are not available in 3" or 4" sizes.

NPT FITTING SCHEDULE:

Size	3/4" ~ 1"	1-1/4"	1-1/2"	2" ~ 4"
Cover Vent	1/8"	1/8"	1/8"	1/8"
Drain	1/4"	1/4"	1/4"	1/2"

REFERENCED STANDARDS & CODES

Code	Description
ASME B16.1	Cast Iron Pipe Flanges and Flanged Fittings
ASME B16.4	Cast Iron Pipe Threaded Fittings

MATERIAL TEMPERATURES

Seat/Seal/Ball	Temp Range
Buna-N (Seal)	-20 ~ 250 °F
Stainless Steel Ball	Max 450 °F

PRESSURE - TEMPERATURE RATING

ASME Class 125	DS 595/695-CI
WOG (Non-shock)	200 PSI @ 150 °F

SCREEN SELECTION GUIDELINES

Size	Liquid	Open Area
3/4" ~ 4"	1/16 (.0625)	41%

1. Max and min temperatures are for reference only. Prolonged use at these temperatures is not recommended for optimal service life.

As †Titan product changes occur, there may be short-term differences between actual product specifications and the information contained within our literature. †Titan FCI reserves the right to make design and specification changes to improve our products without prior notification. When required, request certified drawings. †TITAN is a registered trademark of Titan Flow Control Incorporated.