



## CHECK VALVE ♦ WAFER TYPE ♦ DUAL DISC

### ASME CLASS 900 ♦ CARBON AND STAINLESS STEEL

**MODEL: CV 47-CS**

(CARBON STEEL)

**CV 47-SS**

(STAINLESS STEEL)

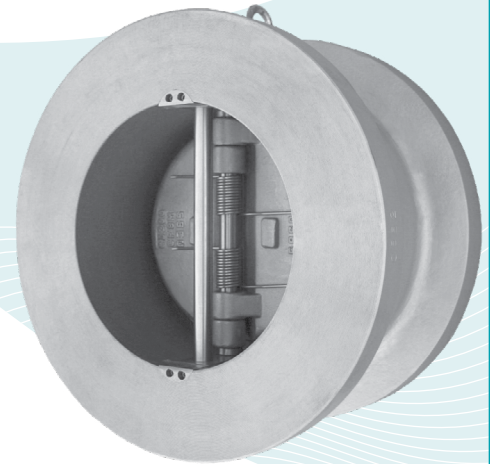

## FEATURES

SIZE RANGE: 2" ~ 24"

LARGER SIZES AVAILABLE

### ♦ COST EFFICIENT DESIGN

LOW WEIGHT AND SHORT LAYING LENGTH PRODUCE SAVINGS IN INITIAL COST, SPACE REQUIREMENTS, AND INSTALLATION WHEN COMPARED TO FULL-BODY, SWING-TYPE CHECK VALVES.

### ♦ MINIMAL HEAD LOSS

CONTOUR OF BODY PROVIDES A SHORT AND STRAIGHT FLOW PATH THAT GENERATES VERY LITTLE TURBULENCE. ADDITIONALLY, THE SPRING-LOADED DISCS ARE DESIGNED WITH VERY LOW CRACKING PRESSURE WHICH REDUCES THE AMOUNT OF ENERGY REQUIRED TO OPEN THE VALVE.

### ♦ QUICK CLOSURE TO REDUCE WATER HAMMER

SHUT-OFF IS ACHIEVED VIA THE FULLY AUTOMATIC, SPRING-ASSISTED DISCS THAT CLOSE NEAR ZERO FLOW VELOCITY. THE LIGHTWEIGHT, SPLIT DISC DESIGN CREATES A POSITIVE SHUTOFF PRIOR TO FLOW REVERSAL AND HELPS TO KEEP SLAMMING AND SURGES TO A MINIMUM.

### ♦ DESIGNED FOR LONG SERVICE LIFE

THE SPRING AND DISCS ARE DESIGNED TO ALLOW THE DISCS TO LIFT LINEARLY BEFORE PIVOTING TO AVOID THE DISC HEAL FROM SCRUBBING THE SEALING SURFACE. ALSO, DISCS ARE EQUIPPED WITH CAST-IN SHOCK BUMPERS THAT HELP TO REDUCE WEAR AND TEAR ON INTERNAL COMPONENTS.

### ♦ FUGITIVE EMISSION DESIGN

THE RETAINER-LESS BODY DESIGN ELIMINATES POTENTIAL LEAK PATHS TO THE ENVIRONMENT SO THERE ARE NO BODY EMISSIONS.

### ♦ RESILIENT AND METAL SEATS

BROAD, LAPPED SEALING SURFACE (METAL) MEETS OR EXCEEDS API 598 TEST REQUIREMENTS. OPTIONAL RESILIENT SEATS (VITON/BUNA) ENSURE A BUBBLE TIGHT SEAL.

## TECHNICAL

PRESSURE/ TEMPERATURE RATING <sup>(1)</sup>  
CS - ASTM A216 GR. WCB - CLASS 900

WOG (Non-shock): 2220 PSI @ 100 °F

PRESSURE/ TEMPERATURE RATING  
SS - ASTM A351 GR. CF8M - CLASS 900

WOG (Non-shock): 2160 PSI @ 100 °F

SEAT MATERIAL  
TEMPERATURE RANGE

VITON: -40 ~ 400 °F  
BUNA-N: -20 ~ 250 °F  
EPDM: -40 ~ 300 °F

SPRING MATERIAL  
TEMPERATURE MAXIMUM

INCONEL X-750: 1000 °F

1. The above listed temperatures are theoretical and may vary during actual operating conditions.
2. Max and min temperatures are for reference only. Prolonged use at these temperatures is not recommended for optimal service life.

## APPLICATIONS

**MARKETS:** WATER & WASTEWATER, PULP & PAPER, CHEMICAL & PETROCHEMICAL, POWER, PETROLEUM AND OIL & GAS

**BUNA-N PROPERTIES:** MOST WIDELY USED ELASTOMER. GOOD FOR MOST PETROLEUM OILS AND FLUIDS, SILICONE GREASES AND OILS, AND COLD WATER. EXCELLENT COMPRESSION SET, TEAR, AND ABRASION RESISTANCE. POOR WEATHER RESISTANCE AND MODERATE HEAT RESISTANCE. NOT RECOMMENDED FOR SEVERE OZONE-RESISTANT APPLICATIONS.

**VITON PROPERTIES:** OFFERS A BROAD RANGE OF CHEMICAL RESISTANCE AND EXCELLENT HEAT RESISTANCE. GOOD MECHANICAL PROPERTIES AND COMPRESSION SET RESISTANCE. OFTEN USED IN APPLICATIONS WHERE NOTHING ELSE WILL WORK. FAIR LOW TEMPERATURE RESISTANCE AND LIMITED HOT-WATER RESISTANCE AND SHRINKAGE.

*The above data represents common market and service applications. No representation or guarantee, expressed or implied, is given due to the numerous variations of concentrations, temperatures and flow conditions that may occur during actual service.*

**TITAN® FLOW CONTROL, INC.**  
**YOUR PIPELINE TO THE FUTURE!**

Tel: 910-735-0000 ♦ Fax: 910-738-3848 ♦ titan@titanfci.com ♦ www.titanfci.com  
290 Corporate Drive ♦ PO Box 7408 ♦ Lumberton, NC 28358



**TITAN® FLOW CONTROL, Inc.**

290 Corporate Drive  
Lumberton, NC 28358  
Tel: 910.735.0000

E-mail: titan@titanfci.com  
Web: www.titanfci.com  
Fax: 910.738.3848

**CHECK VALVE • WAFER TYPE • DUAL DISC**

**MODEL: CV 47-CS (Carbon Steel)  
CV 47-SS (Stainless Steel)**

ASME Class  
900

**BILL OF MATERIALS (1)**

No.	PART	CV 47-CS	CV 47-SS
1	Body	Carbon Steel (4) A216 Gr.WCB	Stainless Steel A351 Gr. CF8M
2	Seat	Metal (5), Buna-N	Metal, Viton
3	Disc (2)	Stainless Steel A351 Gr. CF8M	Stainless Steel A351 Gr. CF8M
4	Spring (2)	Inconel X-750	Inconel X-750
5	Shaft/Stop Pin	Stainless Steel A276 Gr. 316	Stainless Steel A276 Gr. 316
6	Pin Cap (3)	Stainless Steel A276 Gr. 316	Stainless Steel A276 Gr. 316

Illustrations are representative of sizes 6" through 24". Please ask for certified drawings when required.

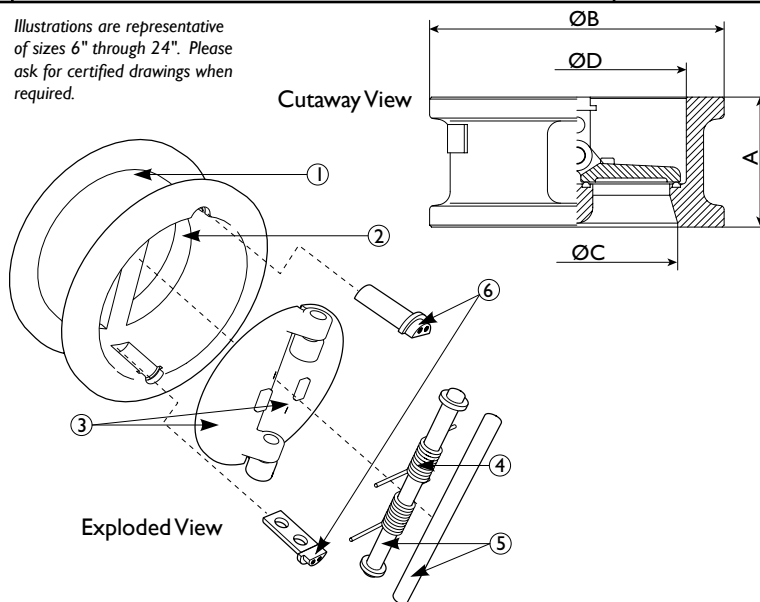

1. Equivalent or better materials may be substituted at the manufacturer's discretion.
2. Denotes recommended spare parts.
3. Pin Cap is only on sizes 6" through 24".
4. Carbon Steel bodies are epoxy painted.
5. Metal seat has stainless steel inlay.

**Additional Design & Technical Notes:**

- The CV 47 has a fugitive emission design. This retainer-less body design eliminates potential leak paths to the environment so there are no body emissions.

**DIMENSIONS AND PERFORMANCE DATA (1)**

SIZE		2	2 1/2	3	4	5	6	8	10	12	14	16	18	20	24
		mm	50	65	80	100	125	150	200	250	300	350	400	450	500
A DIMENSION (2) FACE TO FACE	in	2.75	3.25	3.25	4.00	C/F	6.25	8.125	9.50	11.50	14.00	15.125	17.75	17.75	19.50
	mm	70	83	83	102	C/F	159	206	241	292	356	384	451	451	495
ØB DIMENSION OVERALL DIAMETER	in	5.50	6.50	6.625	8.062	C/F	11.25	14.00	17.00	19.50	20.50	22.50	25.062	27.375	32.875
	mm	140	165	168	205	C/F	286	356	432	495	520	572	636	696	835
ØC DIMENSION INLET DIAMETER	in	2.00	C/F	3.00	3.875	C/F	5.875	7.875	9.375	11.812	12.812	14.937	16.75	18.70	22.437
	mm	50	C/F	76	98	C/F	150	200	238	300	325	380	425	475	570
ØD DIMENSION OUTLET DIAMETER	in	2.187	C/F	3.25	4.25	C/F	6.312	8.25	10.062	11.812	12.812	14.937	16.75	18.687	22.437
	mm	55	C/F	82	108	C/F	160	210	255	300	325	380	425	475	570
ASSEMBLED WEIGHT	lb	13	19	22	38	66	178	300	465	655	875	1170	1322	1390	2650
	kg	6	9	10	17	30	81	136	211	297	397	531	600	630	1202
Flow Coefficient	C <sub>v</sub>	40	80	120	190	380	500	1000	1500	1900	2900	4500	7000	9000	10800
Cracking Pressure (3)	psi	≤ .25	≤ .25	≤ .25	≤ .25	≤ .25	≤ .25	≤ .25	≤ .25	≤ .25	≤ .25	≤ .25	≤ .25	≤ .25	≤ .25

1. Dimensions and weights are for reference only. When required, request certified drawings.
2. Face to face values have a tolerance of ±0.06 in (±2.0 mm) for sizes 10" and lower and a tolerance of ±0.12 in (±3.0 mm) for sizes 12" and larger.
3. Cracking pressure is for horizontal installations only. For vertical installations, please consult factory.

**PRESSURE - TEMPERATURE RATINGS (1)**

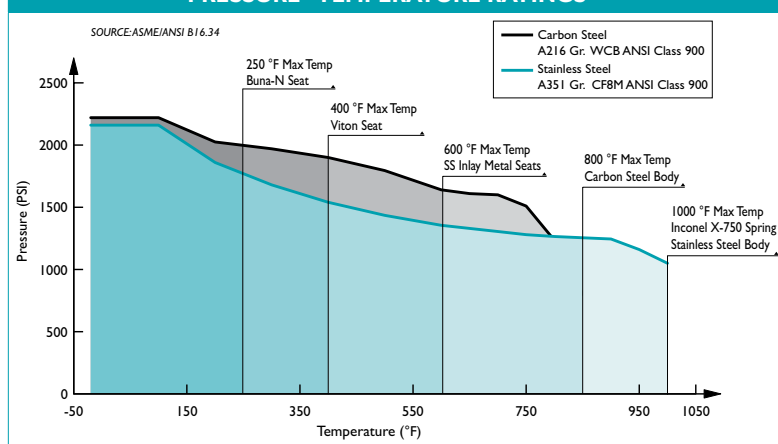

1. The above chart displays the pressure-temperature ratings for the valve's body material per ASME B16.34-1996. Max temperature limits have been added for seat and spring materials.

**REFERENCED STANDARDS & CODES**

CODE	DESCRIPTION
ASME/API 594	Check Valve Design and Manufacture
API 598	Valve Inspection and Testing
API 6D	Pipeline Valves

**PRESSURE - TEMPERATURE RATING**

ASME CLASS 900	A216 Gr.WCB	A351 Gr. CF8M
WOG (Non-shock):	2220 PSI @ 100 °F	2160 PSI @ 100 °F

**SEAT AND SPRING TEMPERATURE RATING**

Seat Material	Range	Spring Material	Max
VITON:	-40 ~ 400 °F	INCONEL X-750:	1000 °F
BUNA-N:	-20 ~ 250 °F		
EPDM:	-40 ~ 300 °F		

1. Max and min temperatures are for reference only. Prolonged use at these temperatures is not recommended for optimal service life.