



TITAN FLOW CONTROL, INC.

## "Y" (WYE) STRAINER ♦ FLANGED ENDS, RAISED FACE

### ASME CLASS 600 ♦ CARBON AND STAINLESS STEEL

NEWLY DESIGNED...

### Gauge Taps

STANDARD ON ALL YS 64 MODELS IN SIZES 2" ~ 12"

## MODELS: YS 64-CS

(CARBON STEEL)

## YS 64-SS

(STAINLESS STEEL)

2" YS 64-SS

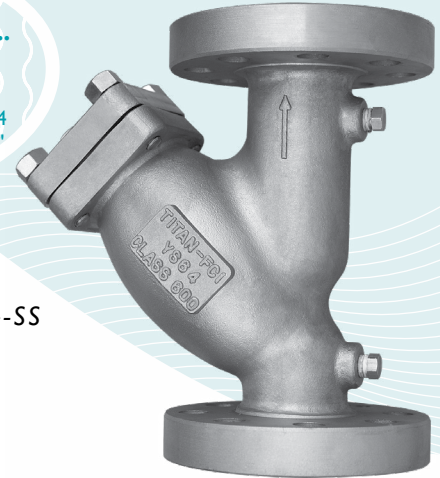

## FEATURES

SIZE RANGE: 1/2" ~ 12"

### ◆ NEW DESIGN WITH GAUGE TAPS

TITAN<sup>†</sup> UNIT YS64 HAS CONVENIENT GAUGE TAPS FURNISHED WITH A PLUG ON BOTH THE INLET AND OUTLET SIDES OF SIZES 2" THROUGH 12". THESE TAPS ALLOW FOR EASY INSTALLATION OF PRESSURE GAUGES TO MONITOR DIFFERENTIAL PRESSURE AND DETERMINE WHEN SCREEN CLEANING IS NECESSARY.

### ◆ LARGE STRAINING CAPACITY

WITH ITS LARGE BODY AND SIZABLE STRAINING ELEMENT, THE YS64 PROVIDES EXCELLENT OPEN AREA RATIOS THAT ARE TYPICALLY TWO-AND-A-HALF TIMES LARGER THAN THE CORRESPONDING PIPELINE.

### ◆ PRECISION MACHINED SEATS

PRECISION MACHINED SCREEN SEATS IN BOTH THE BODY AND CAP HELP TO ENSURE ACCURATE POSITIONING OF THE SCREEN DURING REASSEMBLY AFTER CLEANING. ALSO, THE MACHINED BODY SEATS ENABLE FINER FILTRATION BY PREVENTING DEBRIS BYPASS.

### ◆ SELF-CLEANING CAPABILITY

WITH A TAPPED NPT BLOW-OFF CONNECTION, THIS UNIT CAN BE FITTED WITH A BLOW-DOWN VALVE WHICH FACILITATES CLEANING OF THE STRAINING ELEMENT. PLEASE CONTACT FACTORY FOR MORE INFORMATION.

### ◆ EPOXY PAINTED

CARBON STEEL UNITS ARE EPOXY PAINTED TO HELP RESIST RUST AND CORROSION. TITAN FCI ALSO OFFERS EPOXY COATING AS AN OPTION FOR THE YS64.

### ◆ OPTIONAL COVER DESIGNS

TITAN UNIT YS64 IS AVAILABLE WITH DIFFERENT COVER OPTIONS INCLUDING SWING, CLAMP, AND HINGE TYPE COVERS. PLEASE CONSULT FACTORY FOR MORE INFORMATION ON THESE OPTIONS.

## TECHNICAL

PRESSURE/TEMPERATURE RATING  
CS - ASTM A216 GR. WCB - CLASS 600

WOG (Non-shock): 1480 PSI @ 100 °F

PRESSURE/TEMPERATURE RATING  
SS - ASTM A351 GR. CF8M - CLASS 600

WOG (Non-shock): 1440 PSI @ 100 °F

- The above listed temperatures are theoretical and may vary during actual operating conditions.
- Carbon Steel not recommended for prolonged use above 800 °F.
- Stainless Steel not recommended for prolonged use above 1000 °F.

## APPLICATIONS

**CARBON STEEL PROPERTIES:** CARBON STEEL PERFORMS EXCEPTIONALLY WELL IN HIGH TEMPERATURES, UP TO 800°F IN CONTINUOUS SERVICE. IT PROVIDES HIGH RESISTANCE TO SHOCK, VIBRATION, PIPING STRAINS, AND FIRE AND FREEZING HAZARDS. CARBON STEEL STRAINERS ARE OFTEN USED IN THE OIL AND PETROCHEMICAL INDUSTRIES.

**STAINLESS STEEL PROPERTIES:** STAINLESS STEEL IS COMMONLY SPECIFIED FOR HIGH TEMPERATURE SERVICE, UP TO 1000°F IN CONTINUOUS SERVICE. STAINLESS STEEL STRAINERS ARE COMMONLY FOUND IN THE CHEMICAL, FOOD, AND PHARMACEUTICAL INDUSTRIES.

*The above data represents common market and service applications. No representation or guarantee, expressed or implied, is given due to the numerous variations of concentrations, temperatures and flow conditions that may occur during actual service.*

**TITAN<sup>®</sup> FLOW CONTROL, INC.**  
**YOUR PIPELINE TO THE FUTURE!**

Tel: 910-735-0000 ♦ Fax: 910-738-3848 ♦ titan@titanfci.com ♦ www.titanfci.com  
290 Corporate Drive ♦ PO Box 7408 ♦ Lumberton, NC 28358



**TITAN® FLOW CONTROL, Inc.**

290 Corporate Drive  
Lumberton, NC 28358  
Tel: 910.735.0000

E-mail: titan@titanfci.com  
Web: www.titanfci.com  
Fax: 910.738.3848

**WYE STRAINER**

**YS 64-CS - (Carbon Steel)**

**YS 64-SS - (Stainless Steel)**

**Flanged Ends • Raised Face • Carbon & Stainless Steel**

**ASME Class**

**600**

**BILL OF MATERIALS (1)**

No.	PART	YS 64-CS (3)	YS 64-SS
1	Body	Carbon Steel A216 Gr. WCB	Stainless Steel A351 Gr. CF8M
2	Cover	Carbon Steel A216 Gr. WCB	Stainless Steel A351 Gr. CF8M
3	Straining Element (2)	Stainless Steel	Stainless Steel
4	Gasket (2) (4)	Stainless Steel Spiral Wound	Stainless Steel Spiral Wound
5	Studs	Alloy Steel	Stainless Steel
6	Nuts	Alloy Steel	Stainless Steel
7	NPT Plug Blow-off	Carbon Steel	Stainless Steel
8	NPT Plug Gauge Taps(5)	Carbon Steel	Stainless Steel

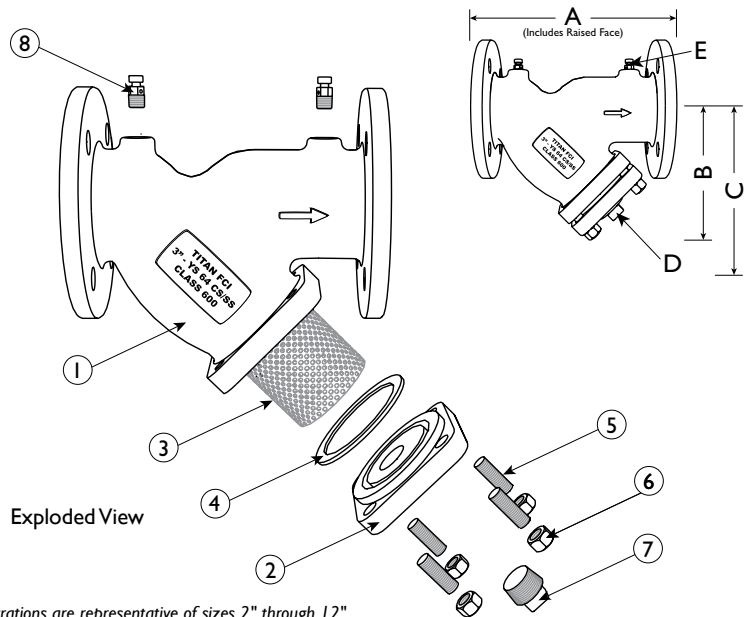

Exploded View

Illustrations are representative of sizes 2" through 12" only. Please ask for certified drawings when required.

1. Bill of Materials represents standard materials. Equivalent or better materials may be substituted at the manufacturer's discretion.
2. Denotes recommended spare parts.
3. Carbon Steel bodies are epoxy painted.
4. A wide range of gasket materials are available; contact factory.
5. Part number 8 (NPT Plug - Gauge Taps) only applies to sizes 2" through 12".

**DIMENSIONS AND PERFORMANCE DATA (1)**

SIZE	in	½	¾	1	1¼	1½	2	2½	3	4	5	6	8	10	12
	mm	15	20	25	32	40	50	65	80	100	125	150	200	250	300
<b>A DIMENSION</b> FACETO FACE (2)	in	6.62	8.31	8.31	10.12	10.25	11.00	12.00	13.50	17.93	22.25	25.62	31.75	37.68	41.00
	mm	169	212	212	258	261	280	305	343	456	566	651	807	958	1041
<b>B DIMENSION</b> CENTER LINE TO BOTTOM	in	3.50	3.75	3.75	5.50	5.50	7.00	8.25	9.25	12.50	15.00	20.00	24.00	28.50	29.31
	mm	89	96	96	140	140	178	210	235	318	381	508	610	724	746
<b>C DIMENSION</b> SCREEN REMOVAL	in	5.00	5.00	5.00	8.00	8.00	10.00	12.50	14.50	19.50	23.00	31.00	38.50	45.50	44.00
	mm	127	127	127	204	204	254	318	369	496	585	788	978	1156	1118
<b>D NPT Plug</b> BLOW-OFF	in	3/8	1/2	1/2	1/2	1/2	1/2	1	1	1 1/2	2	2	2	2	2
	mm	10	15	15	15	15	15	25	25	40	50	50	50	50	50
<b>E NPT Plug</b> GAUGE TAPS	in	N/A	N/A	N/A	N/A	N/A	1/4	1/4	1/4	1/4	1/4	1/4	1/4	1/4	1/4
	mm	N/A	N/A	N/A	N/A	N/A	8	8	8	8	8	8	8	8	8
ASSEMBLED WEIGHT APPROXIMATE	lb	7.5	10.0	13.5	26.0	25.0	32.0	50.0	65.0	125.0	254.0	304.0	526.0	1090.0	1558.0
	kg	3.4	4.5	6.1	11.8	11.3	14.5	22.7	29.5	56.7	115.1	137.9	238.6	493.8	705.9
Flow Coefficient	C <sub>v</sub>	C/F	C/F	C/F	C/F	42	70	110	160	260	400	570	950	1600	2200

1. Dimensions and weights are for reference only. When required, request certified drawings.
2. Face to face dimension includes raised face. These values have a tolerance of ±0.06 in (±2.0 mm) for sizes 10" and lower and a tolerance of ±0.12 in (±3.0 mm) for sizes 12" and larger.

**PRESSURE - TEMPERATURE RATING**

Body Material	A216 Gr. WCB	A351 Gr. CF8M
WOG (Non-shock):	1480 PSI @ 100 °F	1440 PSI @ 100 °F

**SCREEN SELECTION GUIDELINES**

Size	Liquid	Open Area	Steam	Open Area
1/2" - 4"	1/16 (.0625)	41%	1/32 (.033)	28%
5" - 8"	1/8 (.125)	40%	3/64 (.045)	36%
10" - 12"	1/8 (.125)	40%	30 Mesh Lined	44.8%

**REFERENCED STANDARDS & CODES**

CODE	DESCRIPTION
ASME B1.6.5	Pipe Flanges and Flanged Fittings
ASME B1.6.34	Flanged, Threaded, and Welding End

**PRESSURE - TEMPERATURE RATINGS**

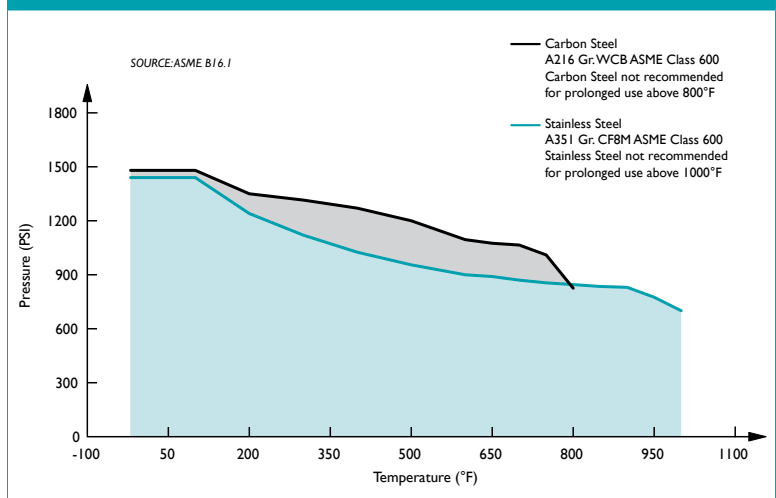

As †Titan product changes occur, there may be short-term differences between actual product specifications and the information contained within our literature. †Titan FCI reserves the right to make design and specification changes to improve our products without prior notification. When required, request certified drawings. †TITAN is a registered trademark of Titan Flow Control Incorporated.