

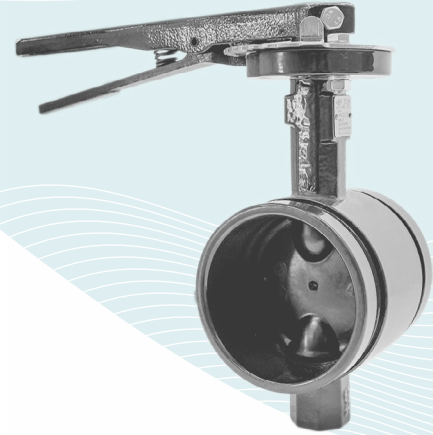

TITAN FLOW CONTROL, INC.

**BUTTERFLY VALVE ♦ RESILIENT SEAT ♦ WOG 300****DUCTILE IRON ♦ GROOVED STYLE**

UL & FM LISTED  
**BF 77G-DI**  
 AVAILABLE



## FEATURES

**MODEL: BF 77G-DI**  
 (DUCTILE IRON)  
 SIZE RANGE: 2"~12"

### ♦ UNIVERSAL MOUNTING FLANGE

THE CAST-IN ACTUATOR FLANGE IS UNIVERSALLY DESIGNED IN ACCORDANCE WITH ISO 5211 STANDARD DIMENSIONS. THE MOUNTING FLANGE CAN ACCOMMODATE ALL TYPES OF OPERATORS SUCH AS: 10-POSITION HANDLE KITS, GEAR OPERATORS, ELECTRIC ACTUATORS, AND PNEUMATIC ACTUATORS. FOR ACTUATORS, TITAN FCI MAY PROVIDE BOTH DIRECT MOUNT AND BRACKET MOUNT DESIGNS. PLEASE CONTACT TITAN FCI ABOUT YOUR SPECIFIC AUTOMATION REQUIREMENTS.

### ♦ EXTENDED NECK

THE EXTENDED NECK PROVIDES CLEARANCE FOR PIPING INSULATION. ALSO, IT ELEVATES MOUNTED ACTUATORS FOR EASIER ACCESS. STEM EXTENSIONS ARE AVAILABLE TO FURTHER ELEVATE THE OPERATING LOCATION OF THE VALVE. PLEASE CONTACT FACTORY FOR ADDITIONAL INFORMATION.

### ♦ QUICK CONNECT GROOVED-ENDS

MODEL BFV 77-G IS A ONE-PIECE BODY CONSTRUCTION WITH GROOVED ENDS THAT MEET AWWA C606-15 REQUIREMENTS. THE GROOVED ENDS ALLOW A QUICKER WELD-FREE CONNECTION WITH OTHER GROOVED COUPLINGS FORMING A LEAK-TIGHT SEAL. GROOVED COUPLINGS USE TWO BOLTS TO CONNECT COMPARED TO OTHER CONNECTIONS MAKING THEM EASIER TO INSTALL AND REMOVE WHEN NEEDED FOR REPAIRS. LUG AND WAFER STYLE BUTTERFLY VALVES ARE ALSO AVAILABLE WITH ASME 125/150 BOLTING PATTERNS.

### ♦ STEM DESIGN

THE DIAGONAL SQUARE STEM DESIGN OFFERS EXCEPTIONALLY HIGH STRENGTH, STABILITY, DEPENDABILITY AND ACCURATE DISC POSITIONING.

### ♦ APPLICABLE STANDARDS

GROOVED END BUTTERFLY VALVES ARE DESIGNED IN ACCORDANCE WITH MSS-SP-67, AND AWWA C606-15 SPECIFICATIONS.

## TECHNICAL

PRESSURE/ TEMPERATURE RATING <sup>(1)</sup>  
 DUCTILE IRON - ASTM A536

WOG (Non-shock): 300 PSI

1. The above listed temperatures are theoretical and may vary during actual operating conditions.
2. Working temperature: Rubber seal 0 - 175° F

## APPLICATIONS

**MARKETS:** COOLING WATER, SLURRY, WASTEWATER TREATMENT, FIRE PROTECTION, LUBRICATION SYSTEM, CHEMICAL OPERATIONS, OIL INDUSTRY, FUEL HANDLING SYSTEMS, POWER GENERATION, FOOD PROCESSING, PHARMACEUTICAL AND MARINE SYSTEMS

**GENERAL APPLICATION:** BUTTERFLY VALVES ARE USED WITHIN A BROAD RANGE OF APPLICATIONS. THEY PERFORM WELL IN LARGE VOLUME WATER APPLICATIONS AND SLURRY APPLICATIONS.

*The above data represents common market and service applications. No representation or guarantee, expressed or implied, is given due to the numerous variations of concentrations, temperatures and flow conditions that may occur during actual service.*

**TITAN® FLOW CONTROL, INC.**  
**YOUR PIPELINE TO THE FUTURE!**

Tel: 910-735-0000 ♦ Fax: 910-738-3848 ♦ titan@titanfci.com ♦ www.titanfci.com  
 290 Corporate Drive ♦ PO Box 7408 ♦ Lumberton, NC 28358



**TITAN® FLOW CONTROL, Inc.**

290 Corporate Drive  
Lumberton, NC 28358  
Tel: 910.735.0000

E-mail: titan@titanfci.com  
Web: www.titanfci.com  
Fax: 910.738.3848

**BUTTERFLY VALVE**  
**BF 77G-DI (Ductile Iron)**

• Grooved Ends

WOG 300

**BILL OF MATERIALS (1)**

No.	PART	BF 77G-DI
1	Body	Ductile Iron ASTM A536
2	Stem	Stainless Steel
3	O-Ring	EPDM or Buna-N
4	Stem	Stainless Steel
5	Disc	Ductile Iron + EPDM or Buna-N
6	Plug (Threaded)	Carbon steel Zinc plated
7	Lever(2)(3)	Ductile Iron ASTM A536
8	Flange Mount Plate	Carbon steel Zinc plated
9	Hex Cap Screws	Carbon steel Zinc plated
10	Plain Washers	Carbon steel Zinc plated
11	Spring Washers	Carbon steel Zinc plated
12	Hex Nuts	Carbon steel Zinc plated

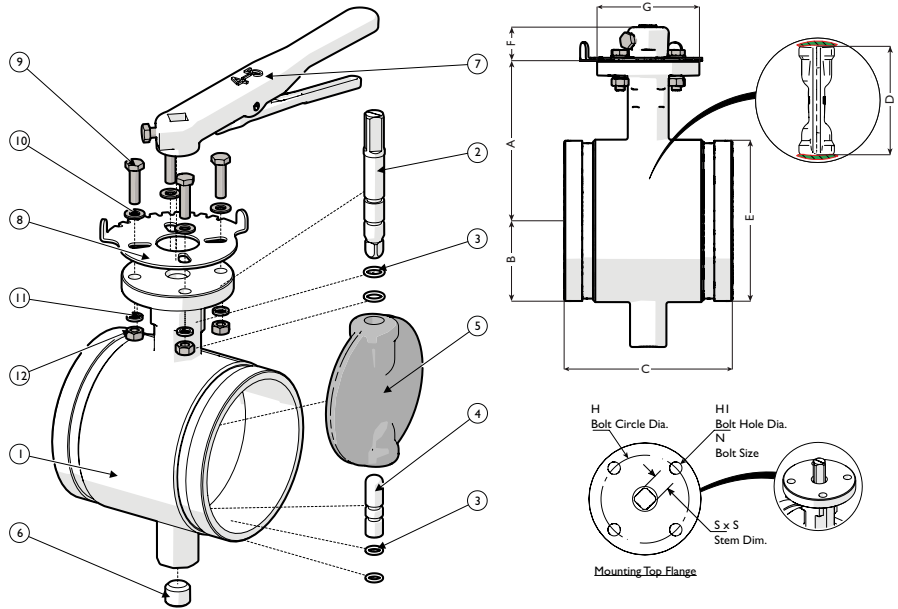

- BOM represents standard materials. Equivalent or better materials may be substituted at the manufacturer's discretion.
- 2 ~ 6" units are standard with lever.
- 8 ~ 12" units are standard with gear operator.

**Additional Design & Technical Notes:**

- Valves are designed to comply with MSS SP-67 Type II
- Valves are tested to comply with MSS SP-67
- Top flange drilling conform to ISO 5211
- Maximum working pressure is 300 PSI for sizes 2" through 12"
- Sizes 2" through 12" have Diagonal square (Diamond) style stems
- Valves can be made silicone free upon request
- Coating: Fusion bonded Epoxy coating in accordance with AWWA C550
- Not recommended for steam service (consult factory)

**DIMENSIONS AND PERFORMANCE DATA (1)**

SIZE	in	2	2 1/2	3	4	5	6	8	10	12
	mm	50	65	80	100	125	150	200	250	300
<b>A DIMENSION</b> CTR. LINE TO TOP (2)	in	3.94	4.53	4.45	5.71	5.55	6.97	7.87	11.02	11.81
	mm	100	115	113	145	141	177	200	280	300
<b>B DIMENSION</b> CTR. LINE TO BOTTOM	in	2.56	2.80	3.19	3.74	4.37	5.24	6.46	7.72	8.90
	mm	65	71	81	95	111	133	164	196	226
<b>C DIMENSION</b> FACE TO FACE	in	3.19	3.82	3.82	4.57	5.83	5.83	5.24	6.26	6.50
	mm	81	97	97	116	148	148	133	159	165
<b>D DIMENSION</b> DISC	in	1.98	2.39	2.99	3.88	4.83	5.83	7.83	9.92	11.83
	mm	50	60	76	98	123	148	199	252	301
<b>E DIMENSION</b> END DIAMETER	in	2.37	2.87	3.50	4.50	5.56	6.63	8.63	10.75	12.75
	mm	60	73	89	114	141	168	219	273	324
<b>F DIMENSION</b> HANDLE HEIGHT	in	1.26	1.26	1.26	1.26	1.26	1.26	1.77	1.77	1.77
	mm	32	32	32	32	32	32	45	45	45
<b>G DIMENSION</b> MOUNT FLANGE DIAMETER	in	3.54	3.54	3.54	3.54	3.54	3.54	4.92	4.92	4.92
	mm	90	90	90	90	90	90	125	125	125
<b>H DIMENSION</b> MOUNT FLANGE B.C.D	in	2.75	2.75	2.75	2.75	2.75	2.75	4.00	4.00	4.00
	mm	70	70	70	70	70	70	102	102	102
<b>HI DIMENSION</b> BOLT HOLE DIAMETER	in	0.394	0.394	0.394	0.394	0.394	0.394	0.472	0.472	0.472
	mm	10	10	10	10	10	10	12	12	12
<b>N-Ø DIMENSION</b> BOLT DIA. SIZE (5)	in	5/16-18	5/16-18	5/16-18	5/16-18	5/16-18	5/16-18	3/8-16	3/8-16	3/8-16
	mm	M8	M8	M8	M8	M8	M8	M10	M10	M10
<b>S X S DIMENSION</b> DIAGONAL SQUARE STEM	in	---	---	---	---	---	---	---	---	---
	mm	11 x 11	11 x 11	11 x 11	14 x 14	14 x 14	17 x 17	17 x 17	22 x 22	22 x 22
<b>ASSEMBLED WEIGHT</b> APPROXIMATE	lb	5.95	7.20	8.05	11.25	16.00	22.60	48.0	68.0	88.0
	kg	2.7	3.2	3.6	5.1	7.28	10.2	21.7	30.8	100.1
<b>Flow Coefficient</b> FULLY OPEN	C <sub>v</sub>	145	225	325	590	1125	1950	3250	5000	7500

- Dimensions, weights, and flow coefficients are provided for reference only. When required, always request certified drawings.
- Face to face values have a tolerance of ±0.06 in (±2.0 mm) for sizes 10" and lower and a tolerance of ±0.12 in (±3.0 mm) for 12".
- Additional accessories and technical data available, please refer to sheets Spec BFVT & BFVA for information.
- Larger sizes and various styles available, contact factory for details.
- Number of Bolts for sizes 2" ~ 12" is Four (4)

As †Titan product changes occur, there may be short-term differences between actual product specifications and the information contained within our literature. †Titan FCI reserves the right to make design and specification changes to improve our products without prior notification. When required, request certified drawings. †TITAN is a registered trademark of Titan Flow Control Incorporated.