



TITAN FLOW CONTROL, INC.

INSTALLATION, OPERATION, AND MAINTENANCE

PREFACE:

This manual contains information concerning the installation, operation, and maintenance of Titan Flow Control (Titan FCI) Globe Style, Silent Check Valves. To ensure efficient and safe operation of Titan FCI Globe Style Check Valves, the instructions in this manual should be thoroughly read and understood. This manual is general in nature and is not meant to take the place of an on-site, process engineer or pipe fitter. As such, Titan FCI recommends that only experienced, skilled personnel be allowed to install and maintain Titan FCI Globe Check Valves. Please retain this manual in a location where it is readily available for reference.

GENERAL INFORMATION:

Titan FCI's Globe Style Check Valves are designed to automatically prevent back-flow in systems where it is desirable to permit flow in one direction and prevent flow in the opposite direction. When the pump starts and the downstream flow creates the required pressure drop in the forward direction, the disc will automatically open. When the pump stops and the flow ceases, the force of the spring will automatically close the disc prior to flow reversal. This creates a positive shutoff against flow reversal and eliminates system surges and water hammer.

For additional information regarding Titan FCI's Globe Style Check Valves, please refer to the engineering specification sheet for each model. Further information may also be obtained from *Titan FCI's Check Valve Selection and Technical Data Guide*.

Prior to selection of a Titan FCI Globe Style Check Valve, the following factors must be determined:

- Material construction requirements of the Check Valve.
- Design and working pressure/temperature requirements.
- Operating conditions (throttling, pressure drop, condensation, flow reversal, operation frequency, etc.).
- Service media type (liquid, gas, abrasive, corrosive, dirty, etc.).
- Pipeline Media Flow-rate and Viscosity.
- Clean Start-up Pressure of the Pipeline.
- Space availability for installation.

Please contact a Titan Design Engineer to assist in the determination of these requirements prior to selection and purchase.



Figure 1: CV 52-DI
ANSI Class 250/300 • Ductile Iron



Figure 2: CV 51-SS
ANSI Class 150 • Stainless Steel

CAUTION:

Titan FCI's Globe Style Check Valves are intended for liquid service that does not exceed 10 ft./sec. They are not recommended for steam service or flow media that contains solids.

GLOBE STYLE CHECK VALVE

1

CVGIOM0306

SERVICE ♦ QUALITY ♦ COMMITMENT

Tel: 910-735-0000 ♦ Fax: 910-738-3848 ♦ titan@titanfci.com ♦ www.titanfci.com
290 Corporate Drive ♦ PO Box 7408 ♦ Lumberton, NC 28358



UNPACKING AND INSPECTION:

Upon receipt of product, it is important to follow these unpacking and inspection procedures.

All Titan FCI Globe Style Check Valves are shipped in specialized shipping containers designed to prevent damage during transportation. If external damage to the shipping container is evident upon receipt of product, please request that a representative of the shipping carrier be present before unpacking the product.

- Carefully open the shipping container, following any instructions that may be marked on the container. Remove all packing material surrounding the Check Valve and carefully lift it from the container. It is recommend to keep the shipping container and all packing material for reuse in storage or reshipment.
- Visually inspect the Check Valve for any signs of damage including scratches, loose parts, broken parts or any other physical damage that may have occurred during shipment. If damage is observed, immediately file a claim with the shipping carrier. Check Valves that are damaged during transportation are the responsibility of the customer. For information regarding Titan FCI's warranty policy, please refer to the last page of this document.
- Before installation, the check valve should be inspected internally for any loose or foreign materials that may have become trapped inside the Check Valve during transportation.
- If the Check Valve is not required to be installed immediately, it should be stored indoors in a clean, dry, consistent temperature environment. It is also recommended to utilize the original shipping container and packing materials to properly store the Check Valve. If long term storage is required, a desiccant may be necessary. This would be based upon the local, environmental storage conditions. Please consult a Titan FCI Design Engineer to assist in this determination.
- When ready to install, remove any preservatives with solvent dampened cloths. Remove any loose material and protective packing material.



Figure 3: CV 50-DI
ANSI Class 150 • Ductile Iron

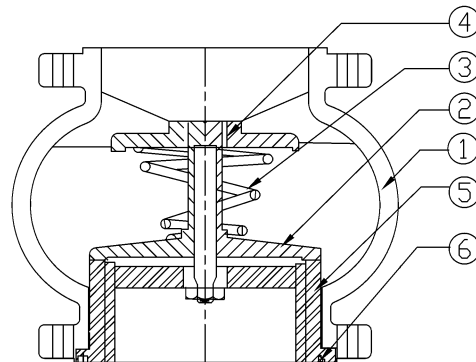

Figure 4: CAD Illustration

PARTS LIST	
No.	PART
1	Body
2	Disc ⁽¹⁾
3	Spring ⁽¹⁾
4	Bushing ⁽¹⁾
5	Seat ⁽¹⁾
6	Bolts

1. Denotes recommended spare parts.



TITAN FLOW CONTROL, INC.

INSTALLATION, OPERATION, AND MAINTENANCE

INSTALLATION:

Pre-Installation Checklist

- Ensure Working conditions (pressure and temperature) are within the specified capacity of the product being installed. Please refer to the Engineering Specification Sheet for each Check Valve model to determine these values.
- Make sure that the construction material of the Check Valve is compatible with the media flowing in the pipeline. Additionally, ensure that the service media is filtered to remove unwanted debris prior to entering the Check Valve. If the service media is not sufficiently clean, debris particles can prevent the Check Valve from sealing correctly and degrade overall performance overtime.
- Inspect sealing surfaces that they are clean and smooth; no nicks or cuts. The pipeline should also be checked for proper alignment. Titan FCI Check Valves should never be utilized to realign an existing piping system.
- For efficient function and improved service life, recognized piping standards stipulate placing Check Valves 5 to 10 pipe diameters from any turbulence producing devices (elbows, pumps, tees, expansions, reductions, and swages).

PRECAUTION:

Titan Globe Style Check Valves are designed for steady flow conditions and are not recommended for use in reciprocating pump, compressor or other types of physical/thermal shock-load applications. In this type of application, the Check Valve will not perform efficiently and will ultimately fail.

PRECAUTION:

Titan Globe Style Check Valves are designed to operate properly for flow rates between 5 ft./sec. to 10 ft./sec.. It is not recommended to exceed the maximum flow rate of 10 ft./sec. or the minimum flow rate of 5 ft./sec..

PRECAUTION:

A Titan FCI strainer should be installed ahead of the pump to ensure protection and proper operation of the check valve and the pump.

INSTALLATION: Continued...

Step 1:

Remove the plastic flange protectors and other packaging materials from the Check Valve.

Step 2:

Orientate the flow arrow (cast into the side of the valve body or printed on the nameplate) in the direction of the pipeline flow. In the correct position, the valve disc will move away from the valve seat, in the direction of the pipeline flow. Titan FCI Globe Style Check Valves can be installed in any position: horizontal, vertical (with upward flow) or any varying angle. For vertical installation with downward flow, please consult factory as a stronger spring may be required.

Step 3:

While supporting the existing pipeline, lift the Check Valve into position. For large or heavy Check Valves, the appropriate material handling equipment must be used in order to prevent injury and possible damage to the Check Valve.

CAUTION:

When lifting the Check Valve, place hooks in the flange holes or slings/chains around the valve body. Never lift the Check Valve by attaching slings/chains to the trim/seat assembly. The trim/seat assembly is not designed to withstand the weight of the unit.

Step 4:

Install a standard, 1/8" thick flange gasket (in accordance with ANSI B16.5) between valve and mating flanges (on both sides). Ensure the flange gaskets are centered correctly to prevent internal leakage.

CAUTION:

Mating flanges can not be raised-face flanges. Titan FCI Globe Style Check Valves can only be mated to flat face flanges.

SERVICE ♦ QUALITY ♦ COMMITMENT

Tel: 910-735-0000 ♦ Fax: 910-738-3848 ♦ titan@titanfci.com ♦ www.titanfci.com

290 Corporate Drive ♦ PO Box 7408 ♦ Lumberton, NC 28358



INSTALLATION: Continued...

Step 5:
Install lubricated flange bolts and hand tighten. Flange bolts should then be tightened using a star or crisscross pattern to evenly load the bolts. This is illustrated in the diagram below.

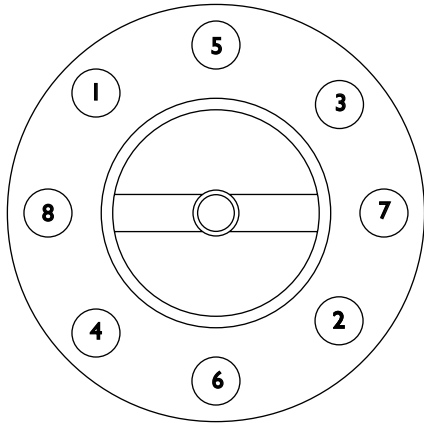

Figure 5: Bolting Pattern

CAUTION:

Excessive bolt torque may damage the Check Valve Flanges. Please refer to established flange bolt torques.

OPERATION:

Start-up Procedure:

Once proper installation has been successfully completed, start the system gradually, at start up as well as after shut down. This eliminates sudden shock to the Check Valve and other equipment in the line.

MAINTENANCE:

Titan FCI Check Valves are designed to provide trouble-free service and seldom require maintenance. If removal of Check Valve is required for inspection, please follow these steps.

MAINTENANCE: Continued...

Valve Removal

CAUTION:

Before removing the Check Valve from the pipeline, the pressure inside the vessel must be reduced to atmospheric via suction or venting. Failure to do so may result in serious bodily injury.

CAUTION:

Before removing the Check Valve from the pipeline, ensure that the media that is flowing in the pipeline is known and any special handling precautions are understood. Please review the Material Safety Data Sheet (MSDS) for that specific fluid.

Step 1:

To remove the Check Valve from the pipeline, first isolate the Check Valve by shutting off the upstream pump and closing the downstream isolation valve. Drain the system as much as possible.

Step 2:

Relieve pressure from both sides of the Check Valve by venting the line.

Step 3:

Loosen the outlet side first, never loosen the inlet side first. Once pressure has been relieved, loosen inlet side.

Step 4:

Remove Check Valve from the pipeline and place the Check Valve with outlet side on the ground. Inspect internal components for wear or damage. If replacement parts are required, please contact Titan Flow Control for repair recommendations.

SPARE PARTS LIST:

For the bill of materials and spare parts listing of each Globe Style Check Valve, please refer to the corresponding Engineering Specification Submittal Sheet.



TITAN FLOW CONTROL, INC.

INSTALLATION, OPERATION, AND MAINTENANCE

MAINTENANCE: Continued...

Trouble Shooting:

Leakage:

Periodic inspections for leakage should be performed. If leakage is present, check the flange gasket and flange bolt torque. In some situations, it may be necessary to isolate the Check Valve by shutting off upstream and downstream valves. Then remove the Check Valve and inspect the seating surfaces for damage.

When removing the Check Valve for inspection, please follow the removal instructions presented in this manual. Always relieve pressure from both sides of the Check Valve before inspection.

Vibration:

Verify that flow rate is within acceptable ranges (5 ft./sec. to 10 ft./sec.). Additionally, verify that the Check Valve is 5 to 10 pipe diameters from any turbulence producing devices (elbows, pumps, tees, expansions, reductions, and swages).

Slamming:

Remove Check Valve from piping system and inspect the spring. Verify that the spring is providing the proper tension.

Restricted Flow:

If flow is halted at the Check Valve, verify that the flow direction arrow (casted into the side of the body or printed on the nameplate) is pointing in the direction of the flow.

WARRANTY:

Seller warrants each of the products and parts sold hereunder, under normal use of service, and subject to user's compliance with any operating instructions and other directions given by seller, to be free from defects in materials or workmanship for a period of one year from date of shipment from seller's plant. Seller's liability, under this warranty, shall be limited to, at the seller's option, to repairing or replacing any such defective product FOB seller's plant in Lumberton, NC, and reimbursing purchaser for shipping costs, subject to the following: (1) Timely receipt of purchaser's written notice that such products are defective. (2) Seller's written authorization to purchaser for the return of such products, (3) the return of such products to seller with shipping charges prepaid and (4) seller's inspection of and confirmation that such products are defective in materials or workmanship. If seller's inspection shows that the products returned are defective due to dirt, rust or any foreign material not attributable to seller: improper usage, over tightening on threads, abuse or incorrect assembly in the field, or other cause not due to seller's improper manufacture, seller will, subject to purchaser's written authorization, repair or replace such products at cost. Seller's factory inspection and testing reports will be made available to purchaser upon request.

THIS WARRANTY IS IN LIEU OF ANY OTHER WARRANTIES, EXPRESS OR IMPLIED, INCLUDING ANY IMPLIED WARRANTY OF FITNESS OR MERCHANTABILITY. SELLER SHALL NOT BE LIABLE FOR ANY SPECIAL, INCIDENTAL, OR CONSEQUENTIAL DAMAGES. NO REPRESENTATIVE OR SELLER HAS AUTHORITY TO MAKE ANY REPRESENTATIONS OR WARRANTIES, EXCEPT AS STATED HEREIN.

SERVICE ❖ QUALITY ❖ COMMITMENT

Tel: 910-735-0000 ❖ Fax: 910-738-3848 ❖ titan@titanfci.com ❖ www.titanfci.com

290 Corporate Drive ❖ PO Box 7408 ❖ Lumberton, NC 28358