



TITAN FLOW CONTROL, INC.

SIMPLEX BASKET STRAINER ♦ ANSI CLASS 150 FLAT FACE FIBERGLASS REINFORCED PLASTIC (FRP)

MODELS: BS 55-FRP
(FIBERGLASS)

SIZES: 4" ~ 20"



FEATURES

- ♦ **STANDARD GRADE FRP DESIGNED FOR COMMERCIAL SYSTEMS**
FOR LOW PRESSURE/TEMPERATURE APPLICATIONS, TITAN FCI OFFERS OUR STANDARD GRADE FRP STRAINER CONSTRUCTED FROM ISOPHTHALIC POLYESTER WITH STAINLESS STEEL BASKET INSERTS. PRESSURE TESTED TO 75 PSI. FLANGED CONNECTIONS ARE DRILLED TO 150 LB ANSI STANDARD.
- ♦ **PREMIUM GRADE FRP ALSO AVAILABLE**
FOR MORE SEVERE SERVICE CONDITIONS, TITAN FCI CAN PROVIDE A PREMIUM GRADE FRP STRAINER CONSTRUCTED FROM EITHER EPOXY VINYL ESTER OR CHLORENDIC POLYESTER. THIS GRADE OF FRP PROVIDES SUPERB CORROSIVE, ABRASIVE AND HEAT RESISTANCE AND IS APPROPRIATE FOR SERVICE CONDITIONS UP TO 150 PSI WOG. IT IS A LOGICAL ALTERNATIVE TO RUBBER LINED STRAINERS AS WELL AS STRAINERS CONSTRUCTED FROM HIGH COST, EXOTIC ALLOYS SUCH AS ALLOY 20, HASTELLOY-C, MONEL, AND ALUMINUM BRONZE.
- ♦ **AVAILABLE AS A REDUCING STRAINER**
THE OUTLET SIZE CAN BE SIZED SMALLER (CONCENTRICALLY OR ECCENTRICALLY) THAN THE INLET SIZE TO ALLOW FOR LINE SIZE REDUCTION. ADDITIONALLY, LARGER STRAINER BODIES CAN BE FITTED WITH BOTH SMALLER INLET AND OUTLET SIZES IF A LARGER BASKET AREA IS DESIRED FOR EXTRA CAPACITY.
- ♦ **UNIQUE FEATURES**
QUICK-OPENING COVER, HIGH STRENGTH-TO-WEIGHT RATIO, LOW INSTALLATION COST, FIELD REPAIRABLE AND SEE-THROUGH ACRYLIC COVER. ON LARGER STRAINERS, THE COVER CAN BE CONSTRUCTED FROM FRP WITH AN CLEAR ACRYLIC 8" DIAMETER VIEWPORT.
- ♦ **LOWER LOSSES - INCREASED TIME BETWEEN CLEANING**
THE FRP SERIES STRAINERS ARE BUILT WITH A LARGE OUTLET AREA IN THE BASKET CHAMBER. THIS RESULTS IN VERY LOW PRESSURE LOSSES INITIALLY AND MUCH GREATER DEBRIS LOADING BEFORE THE PRESSURE DROP ACROSS THE STRAINER RISES TO THE POINT WHERE CLEANING IS REQUIRED.

TECHNICAL

MAX WORKING PRESSURE (NON-SHOCK)
ISOPHTHALIC POLYESTER CONSTRUCTION
50 PSI @ 80 °F
EPOXY VINYL ESTER OR CHLORENDIC POLYESTER CONSTRUCTION
150 PSI @ 150 °F

APPLICATIONS

MARKETS: CHEMICAL PROCESSING, WATER TREATMENT, FOOD PROCESSING, PULP AND PAPER MILLS, STEEL PROCESSING, PHARMACEUTICAL INDUSTRY, AND POWER PLANTS.

SERVICE: ACID PLANTS, PICKLING, PLATING, CHEMICAL STRAINING (ACIDS AND BASES), HIGH PURITY PROCESSES, AND SEA/BRACKISH WATER.

The above data represents common market and service applications. No representation or guarantee, expressed or implied, is given due to the numerous variations of concentrations, temperatures and flow conditions that may occur during actual service.

TITAN FLOW CONTROL, INC.

YOUR PIPELINE TO THE FUTURE!

Tel: 910-735-0000 ♦ Fax: 910-738-3848 ♦ titan@titanfci.com ♦ www.titanfci.com
290 Corporate Drive ♦ PO Box 7408 ♦ Lumberton, NC 28358



TITAN FLOW CONTROL, Inc.

290 Corporate Drive
Lumberton, NC 28358
Tel: 910.735.0000

E-mail: titan@titanfci.com
Web: www.titanfci.com
Fax: 910.738.3848

SIMPLEX BASKET STRAINER
BS 55-FRP (FIBERGLASS)
Fiberglass Reinforced Plastic • Flat Face

ANSI Class
150 lb

BILL OF MATERIALS (1)

No.	PART	BS 55-FRP
1	Body	Fiberglass Reinforced Plastic
2	Cover	Acrylic or Fiberglass Reinforced Plastic
3	Basket (2)	Stainless Steel Type 304
4	Hand Knobs	Fiberglass Reinforced Plastic with Stainless Steel Insert
5	Eye Bolts	Stainless Steel
6	O-Rings (2)	Ethylene Propylene

1. Bill of Materials represents standard materials. Equivalent or better materials may be substituted at the manufacturer's discretion.

2. Denotes recommended spare parts.

Additional Design and Technical Notes:

• Titan FCI also offers fiberglass larger-sized simplex strainers and duplex strainers. Please contact factory for more information.

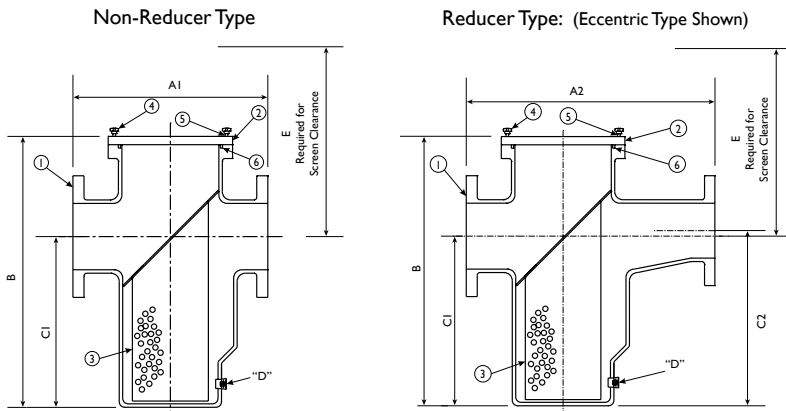

Illustrations are for representational purposes only. Please contact factory for certified drawings when required.

DIMENSIONS AND WEIGHT DATA (1)

Inlet	Outlet	A1 (2) (Face-to-Face) Non-Reducing & Std. Reducing Units Only		A2 (2) (Face-to-Face) Concentric & Eccentric Reducing Units Only		B (Overall Height) All Units		C1 (Centerline-to-Bottom) All Units		C2 (Centerline-to-Bottom) Eccentric Reducing Only		D (Drain Plug)		E (Screen Clearance)		Weight (Approximate)	
		in	mm	in	mm	in	mm	in	mm	in	mm	in	mm	in	mm	lb	kg
4	4	16.625	422	---	---	21.5	546	12.0	304	---	---	3/4	20	31	787	40	18.1
4	3	16.625	422	20.625	523	21.5	546	12.0	304	12.5	317	3/4	20	31	787	40	18.1
4	2.5	16.625	422	20.625	523	21.5	546	12.0	304	13.75	349	3/4	20	31	787	40	18.1
4	2	16.625	422	20.625	523	21.5	546	12.0	304	13.0	330	3/4	20	31	787	40	18.1
6	6	17.625	447	---	---	25.25	641	15.5	393	---	---	1 1/4	32	35	889	52	23.6
6	5	17.625	447	22.625	574	25.25	641	15.5	393	16.0	406	1 1/4	32	35	889	52	23.6
6	4	17.625	447	22.625	574	25.25	641	15.5	393	16.5	419	1 1/4	32	35	889	52	23.6
6	3	---	---	22.625	574	25.25	641	15.5	393	17.0	431	1 1/4	32	35	889	52	23.6
6	2.5	---	---	22.625	574	25.25	641	15.5	393	17.5	444	1 1/4	32	35	889	52	23.6
8	8	23.5	596	---	---	30.25	768	17.5	444	---	---	1 1/2	40	45	1143	85	38.0
8	6	23.5	596	31.0	787	30.25	768	17.5	444	18.5	469	1 1/2	40	45	1143	85	38.0
8	5	23.5	596	31.0	787	30.25	768	17.5	444	19.0	482	1 1/2	40	45	1143	85	38.0
8	4	---	---	31.0	787	30.25	768	17.5	444	19.5	495	1 1/2	40	45	1143	85	38.0
8	3	---	---	31.0	787	30.25	768	17.5	444	20.0	508	1 1/2	40	45	1143	85	38.0
10	10	28.75	730	---	---	34.75	882	21.5	546	---	---	1 1/2	40	48	1219	112	50.0
10	8	28.75	730	38.75	984	34.75	882	21.5	546	22.5	571	1 1/2	40	48	1219	112	50.0
10	6	---	---	38.75	984	34.75	882	21.5	546	23.5	596	1 1/2	40	48	1219	112	50.0
10	5	---	---	38.75	984	34.75	882	21.5	546	24.0	609	1 1/2	40	48	1219	112	50.0
10	4	---	---	38.75	984	34.75	882	21.5	546	24.5	622	1 1/2	40	48	1219	112	50.0
12	12	31.5	800	---	---	37.5	952	23.0	584	---	---	2	50	52	1320	127	57.0
12	10	31.5	800	41.5	1054	37.5	952	23.0	584	24.0	609	2	50	52	1320	127	57.0
12	8	---	---	41.5	1054	37.5	952	23.0	584	25.0	635	2	50	52	1320	127	57.0
12	6	---	---	41.5	1054	37.5	952	23.0	584	26.0	660	2	50	52	1320	127	57.0
12	5	---	---	41.5	1054	37.5	952	23.0	584	26.5	673	2	50	52	1320	127	57.0
14	14	42.0	1066	---	---	48.0	1219	31.0	787	---	---	C/F	C/F	65	1651	340	154.0
14	12	42.0	1066	52.0	1320	48.0	1219	31.0	787	32.0	812	C/F	C/F	65	1651	340	154.0
14	10	---	---	52.0	1320	48.0	1219	31.0	787	33.0	838	C/F	C/F	65	1651	340	154.0
14	8	---	---	52.0	1320	48.0	1219	31.0	787	34.0	863	C/F	C/F	65	1651	340	154.0
14	6	---	---	52.0	1320	48.0	1219	31.0	787	35.0	889	C/F	C/F	65	1651	340	154.0
16	16	42.0	1066	---	---	48.0	1219	31.0	787	---	---	C/F	C/F	65	1651	360	163.0
16	14	42.0	1066	52.0	1320	48.0	1219	31.0	787	32.0	812	C/F	C/F	65	1651	360	163.0
16	12	---	---	52.0	1320	48.0	1219	31.0	787	33.0	838	C/F	C/F	65	1651	360	163.0
16	10	---	---	52.0	1320	48.0	1219	31.0	787	34.0	863	C/F	C/F	65	1651	360	163.0
16	8	---	---	52.0	1320	48.0	1219	31.0	787	35.0	889	C/F	C/F	65	1651	360	163.0
18	18	42.0	1066	---	---	48.0	1219	31.0	787	---	---	C/F	C/F	65	1651	380	172.0
18	16	42.0	1066	52.0	1320	48.0	1219	31.0	787	32.0	812	C/F	C/F	65	1651	380	172.0
18	14	---	---	52.0	1320	48.0	1219	31.0	787	33.0	838	C/F	C/F	65	1651	380	172.0
18	12	---	---	52.0	1320	48.0	1219	31.0	787	34.0	863	C/F	C/F	65	1651	380	172.0
18	10	---	---	52.0	1320	48.0	1219	31.0	787	35.0	889	C/F	C/F	65	1651	380	172.0
20	20	42.0	1066	---	---	48.0	1219	32.5	825	---	---	C/F	C/F	68	1727	380	172.0
20	18	42.0	1066	52.0	1320	48.0	1219	32.5	825	33.5	850	C/F	C/F	68	1727	380	172.0
20	16	---	---	52.0	1320	48.0	1219	32.5	825	34.5	876	C/F	C/F	68	1727	380	172.0
20	14	---	---	52.0	1320	48.0	1219	32.5	825	35.5	901	C/F	C/F	68	1727	380	172.0
20	12	---	---	52.0	1320	48.0	1219	32.5	825	36.5	927	C/F	C/F	68	1727	380	172.0

1. Dimensions and weights are for reference only. When required, request certified drawings.

2. Face to face values have a tolerance of ±0.06 in (±2.0 mm) for sizes 10" and lower and a tolerance of ±0.12 in (±3.0 mm) for sizes 12" and larger.

Titan FCI makes every effort to ensure the information presented on our literature accurately reflects exact product specifications. However, as product changes occur, there may be short-term differences between actual product specifications and the information contained within our literature. Titan FCI reserves the right to make design and specification changes to improve our products without prior notification. When required, request certified drawings.