



TITAN FLOW CONTROL, INC.

BLOW-OFF DRAIN VALVE ♦ HIGH PRESSURE BALL VALVE

3000 WOG ♦ STAINLESS STEEL ♦ TWO PIECE DESIGN

MODELS:

BV 24 (3000 WOG - Female x Female)

BV 25 (3000 WOG - Male x Female)

1/4" THROUGH 2"

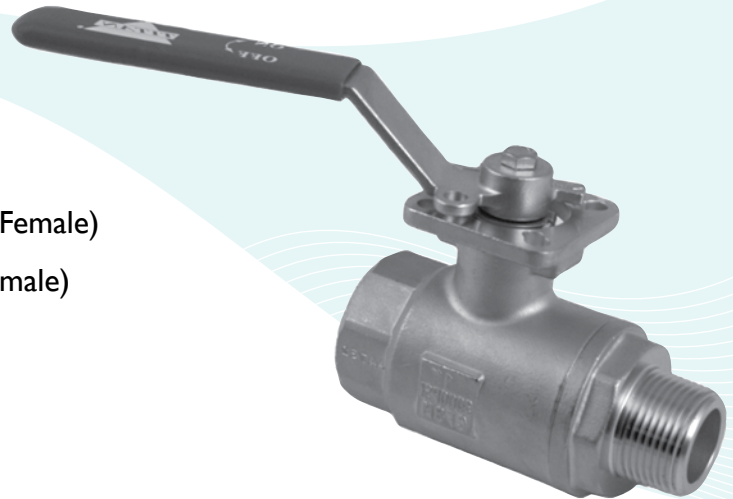

FEATURES

- ♦ FULL PORT DESIGN OFFERS COMPLETE AND RAPID CLEANING OF STRAINER SCREEN; SIZE 2" IS REDUCED PORT
- ♦ IDEAL BLOW-OFF VALVE FOR HIGH PRESSURE STRAINERS ANSI CLASS 600, 900, AND 1500
- ♦ DIRECT MOUNT ACTUATION - MEETS ISO 5211
- ♦ OPTIONAL SAFETY "DEAD-MAN", SPRING RETURN HANDLE IS AVAILABLE
- ♦ LOCKING HANDLE WITH QUICK QUARTER TURN OPERATION
- ♦ MALE THREAD ENDS MOUNT DIRECTLY INTO STRAINER BLOW-OFF CONNECTION
- ♦ PROFESSIONALLY INSTALLED AT OUR FACTORY ENSURES QUALITY AND HELPS TO REDUCE SHIPPING AND LABOR COSTS

TECHNICAL

PRESSURE/TEMPERATURE RATING

BODY: CF8M STAINLESS STEEL

WOG (Non-shock): 3000 PSI @ 100 °F

MAX LIQUID: 80 PSI @ 400 °F

MAX STEAM: 150 PSI @ 366 °F

BALL SEAT: DELRIN

TEMPERATURE: -20 °F ~ 180 °F

SHOWN WITH OPTIONAL
SPRING-RETURN
HANDLE

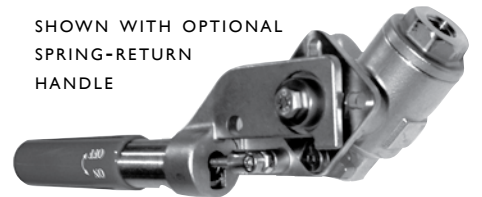

APPLICATIONS

SCREEN CLEANING: DURING NORMAL USE, THE STRAINER SCREEN WILL BECOME CLOGGED WITH FOREIGN MATTER CAUSING THE DIFFERENTIAL PRESSURE TO INCREASE. ONCE THE DIFFERENTIAL PRESSURE HAS REACHED AN UNACCEPTABLE VALUE, BLOW-DOWN CLEANING IS RECOMMENDED. IT IS NOT ADVISABLE TO ALLOW THE DIFFERENTIAL PRESSURE TO INCREASE BY 20 PSI AS THIS MAY CAUSE THE SCREEN TO FAIL AND POSSIBLY DAMAGE DOWNSTREAM EQUIPMENT. IF THE DIFFERENTIAL PRESSURE IS NOT RESTORED TO NORMAL PARAMETERS AFTER BLOW-DOWN CLEANING THEN THE SCREEN MUST BE REMOVED AND CLEANED OR REPLACED.

HAVE TITAN PROFESSIONALLY INSTALL A BV 24 OR BV 25 WHEN PURCHASING A TITAN Y-STRAINER. NOT ONLY WILL YOU BE ASSURED THAT IT IS INSTALLED CORRECTLY, BUT YOU MAY SAVE ON SHIPPING COSTS AS WELL.

SELF-CLEANING Y-STRAINER



TITAN FLOW CONTROL, INC.

YOUR PIPELINE TO THE FUTURE!

Tel: 910-735-0000 ♦ Fax: 910-738-3848 ♦ titan@titanfci.com ♦ www.titanfci.com
290 Corporate Drive ♦ PO Box 7408 ♦ Lumberton, NC 28358



TITAN FLOW CONTROL, Inc.
 290 Corporate Drive
 Lumberton, NC 28358
 Tel: 910.735.0000
 Fax: 910.738.3848

E-mail: titan@titanfci.com
 Web: www.titanfci.com

**BLOW-OFF DRAIN VALVE
 HIGH PRESSURE, DIRECT MOUNT BALL VALVE**

**MODELS: BV 24 (female x female)
 BV 25 (male x female)**

Working Pressure:
 3000 PSI

BILL OF MATERIALS (1)

No.	PART	MATERIAL	QTY
1	Body	CF8M	1
2	End Cap	CF8M	1
3	Ball	CF8M	1
4	Antistatic Stem	T-316 SS	1
5	Ball Seat (2)	DELTRIN	2
6	Ball Seal (2)	PTFE	1
7	Thrust Washer (2)	DELTRIN	1
8	Stem Packing (2)	PTFE	1
8A	O-Ring (2)	VITON	1
9	Thrust Washer (2)	50%-SS 50%-PTFE	1
10	Stem Nut	T-304 SS	1
11	Lock Saddle	T-304 SS	1
12	Handle	T-304 SS	1
13	Stop Bolt	T-304 SS	1
14	Stop Nut	T-304 SS	1
15	Stop Washer	T-304 SS	1
16	Handle Bolt	T-304 SS	1
17	Handle Sleeve	VINYL	1

- BOM represents standard materials. Equivalent or better materials may be substituted at the manufacturer's discretion.
- Denotes recommended spare parts.

Design Notes:

- Two-piece direct mount ball valve
- Working pressure: 3000 psi
- Size: 1/4" ~ 1 1/2" full port - Size: 2" reduced port
- Integrated ISO-5211 mounting pad
- Square stems allows direct mounting to actuator, no additional hardware required
- Blow-out proof stem design
- Anti-static device standard applied between stem to body and stem to ball
- Stem with O-Ring maintains stem alignment, reduces packing side loading and wear
- Fire design complies with API 607-4

DIMENSIONS AND PERFORMANCE DATA

SIZE	in	1/4	3/8	1/2	3/4	1	1 1/4	1 1/2	2
	mm	8	10	15	20	25	32	40	50
ØID	in	.381	.381	.500	.688	.870	1.141	1.366	1.366
	mm	9.7	9.7	12.7	17.5	22.1	29.0	34.7	34.7
ØA	in	F03	F03	F03	F03	F04	F04	F05	F05
	mm	F03	F03	F03	F03	F04	F04	F05	F05
ØB	in	F04	F04	F04	F04	F05	F05	F07	F07
	mm	F04	F04	F04	F04	F05	F05	F07	F07
C	in	4.960	4.960	4.960	4.960	6.141	6.141	7.125	7.125
	mm	126	126	126	126	156	156	181	181
□E	in	.354	.354	.354	.354	.433	.433	.551	.551
	mm	9	9	9	9	11	11	14	14
OF	in	1.019	1.019	1.283	1.511	1.858	2.318	2.606	3.228
	mm	26	26	33	38	47	59	66	82
G	in	1.614	1.614	1.614	1.724	2.106	2.322	2.960	2.960
	mm	41	41	41	44	54	59	75	75
h	in	.314	.314	.314	.314	.393	.393	.511	.511
	mm	8	8	8	8	10	10	13	13
H	in	2.834	2.834	2.834	2.874	3.425	3.661	4.488	4.488
	mm	72	72	72	73	87	93	114	114
L	in	2.952	2.952	2.952	3.188	3.582	4.330	4.763	5.708
	mm	75	75	75	81	91	110	121	145
LI	in	3.500	3.622	3.622	3.897	4.448	5.003	5.551	6.102
	mm	89	92	92	99	113	127	141	155
D	in	.448	.590	.590	.629	.787	.826	.905	.994
	mm	11	15	15	16	20	21	23	25
T	NPT	NPT	NPT	NPT	NPT	NPT	NPT	NPT	NPT
Approximate Weight	lb	1.5	1.5	1.5	2.0	3.2	5.0	8.4	10.7
	kg	.7	.7	.7	.9	1.5	2.3	3.8	4.9
Torque Flow Coef.	in/lb	104	104	130	156	208	390	468	468
	C _v	5.3	8	19	35	50	110	180	210

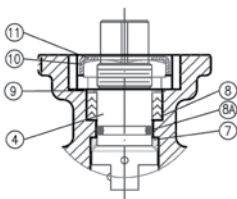
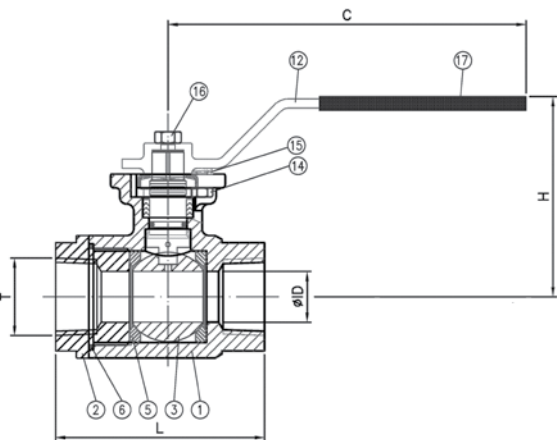

Stem Section Side View

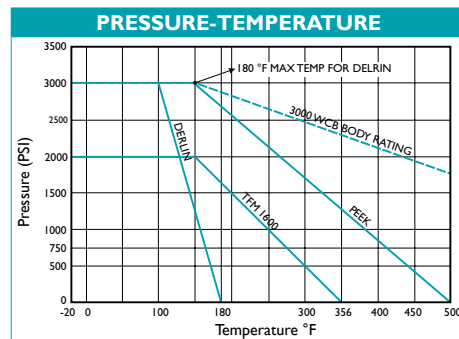

TEST PRESSURE

TYPE	PSI
SEAT (AIR)	80 PSI
SHELL (HYDROSTATIC)	4500 PSI

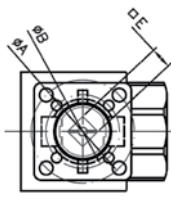
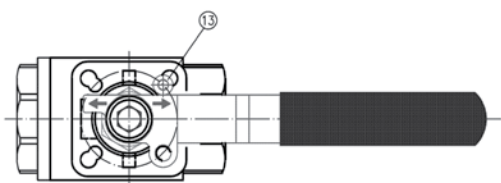

Stem Section Top View

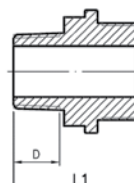

Male Ends

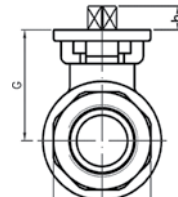

Female Ends

Titan FCI makes every effort to ensure the information presented on our literature accurately reflects exact product specifications. However, as product changes occur, there may be short-term differences between actual product specifications and the information contained within our literature. Titan FCI reserves the right to make design and specification changes to improve our products without prior notification. When required, request certified drawings.