



TITAN FLOW CONTROL, INC.

CHECK VALVE ♦ WAFER TYPE ♦ DUAL DISC

ANSI CLASS 150 ♦ DUCTILE IRON BODY

MODEL: CV 41-DI

Body: Ductile Iron
 Seats: Buna, Viton & EPDM
 Discs: Stainless Steel & Bronze

SIZES 2" ~ 6" PROVIDE
 DUAL PRESSURE SERVICE
 ANSI CLASS 150/300
 (Scalloped Design)

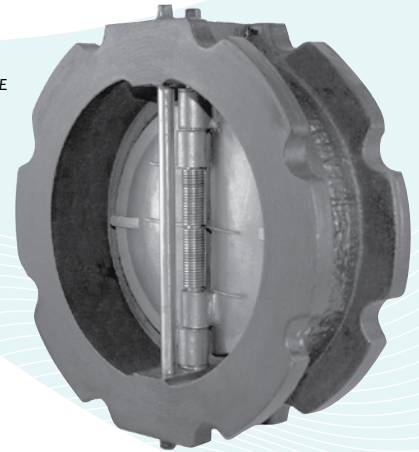

FEATURES

- ♦ **COST EFFICIENT DESIGN**
 LOW WEIGHT AND SHORT LAYING LENGTH PRODUCE SAVINGS IN INITIAL COST, SPACE REQUIREMENTS, AND INSTALLATION WHEN COMPARED TO FULL-BODY, SWING-TYPE CHECK VALVES.
- ♦ **MINIMAL HEAD LOSS**
 CONTOUR OF BODY PROVIDES A SHORT AND STRAIGHT FLOW PATH THAT GENERATES VERY LITTLE TURBULENCE. ADDITIONALLY, THE SPRING-LOADED DISCS ARE DESIGNED WITH VERY LOW CRACKING PRESSURE WHICH REDUCES THE AMOUNT OF ENERGY REQUIRED TO OPEN THE VALVE.
- ♦ **QUICK CLOSURE TO REDUCE WATER HAMMER**
 SHUT-OFF IS ACHIEVED VIA THE FULLY AUTOMATIC, SPRING-ASSISTED DISCS THAT CLOSE NEAR ZERO FLOW VELOCITY. THE LIGHTWEIGHT, SPLIT DISC DESIGN CREATES A POSITIVE SHUTOFF PRIOR TO FLOW REVERSAL AND HELPS TO KEEP SLAMMING AND SURGES TO A MINIMUM.
- ♦ **DUCTILE IRON BODY**
 DUCTILE IRON BODY MAINTAINS THE ANTI-CORROSIVE PROPERTIES OF CAST IRON WHILE ACHIEVING A YIELD STRENGTH COMPARABLE TO CARBON STEEL. DUCTILE IRON ALSO OFFERS HIGHER PRESSURE/TEMPERATURE RATINGS THAN CAST IRON.
- ♦ **RESILIENT SOFT SEATS**
 RESILIENT SOFT SEATS (EPDM, VITON OR BUNA) ENSURE A BUBBLE TIGHT SEAL THAT MEETS OR EXCEEDS API 598 TEST REQUIREMENTS.
- ♦ **VERSATILE DESIGN**
 SIZES 2" THROUGH 6" ARE DESIGNED TO FIT BOLT CIRCLE PATTERNS FOR BOTH CAST IRON ANSI CLASSES 125/300 AND DUCTILE IRON ANSI CLASSES 150/300.

SIZES: 2" ~ 24"

LARGER SIZES AVAILABLE
 UPON REQUEST

TECHNICAL

PRESSURE/TEMPERATURE RATING
 DI - ASTM A536 - CLASS 150 - 2" ~ 24"

WOG (Non-shock): 250 PSI @ 100 °F

PRESSURE/TEMPERATURE RATING
 DI - ASTM A536 - CLASS 300 - 2" ~ 6" only

WOG (Non-shock): 640 PSI @ 100 °F

SEAT MATERIAL
 TEMPERATURE RANGE

EPDM: -20 ~ 300 °F
 BUNA-N: -20 ~ 250 °F
 VITON: -40 ~ 400 °F

SPRING MATERIAL
 MAXIMUM TEMPERATURE

Series 300 Stainless Steel: 450 °F

APPLICATIONS

BUNA-N PROPERTIES: MOST WIDELY USED ELASTOMER. GOOD FOR MOST PETROLEUM OILS AND FLUIDS, SILICONE GREASES AND OILS, AND COLD WATER. EXCELLENT COMPRESSION SET, TEAR, AND ABRASION RESISTANCE. POOR WEATHER RESISTANCE AND MODERATE HEAT RESISTANCE. NOT RECOMMENDED FOR SEVERE OZONE-RESISTANT APPLICATIONS.

VITON PROPERTIES: OFFERS A BROAD RANGE OF CHEMICAL RESISTANCE AND EXCELLENT HEAT RESISTANCE. GOOD MECHANICAL PROPERTIES AND COMPRESSION SET RESISTANCE. OFTEN USED IN APPLICATIONS WHERE NOTHING ELSE WILL WORK. FAIR LOW TEMPERATURE RESISTANCE AND LIMITED HOT-WATER RESISTANCE AND SHRINKAGE.

EPDM PROPERTIES: PROBABLY THE MOST WATER RESISTANT RUBBER AVAILABLE. IT HAS GOOD RESISTANCE TO MILD ACIDS, ALKALIS, SILICONE OILS/GREASES, KETONES, ALCOHOLS AND OTHER POLAR SOLVENTS. IT IS NOT RECOMMENDED FOR USE WITH PETROLEUM OILS, DI-ESTER LUBRICANTS, MINERAL OILS, NON-POLAR SOLVENTS OR AROMATIC FUELS.

The above data represents common market and service applications. No representation or guarantee, expressed or implied, is given due to the numerous variations of concentrations, temperatures and flow conditions that may occur during actual service.

TITAN FLOW CONTROL, INC.

YOUR PIPELINE TO THE FUTURE!

Tel: 910-735-0000 ♦ Fax: 910-738-3848 ♦ titan@titanfci.com ♦ www.titanfci.com
 290 Corporate Drive ♦ PO Box 7408 ♦ Lumberton, NC 28358



TITAN FLOW CONTROL, Inc.

290 Corporate Drive
Lumberton, NC 28358
Tel: 910.735.0000

E-mail: titan@titanfci.com
Web: www.titanfci.com
Fax: 910.738.3848

CHECK VALVE • WAFER TYPE • DUAL DISC

MODEL: CV 41-DI (Ductile Iron Body)

Buna-N, Viton, or EPDM Seats
Stainless Steel or Bronze Discs

ANSI
Class
150 lb

BILL OF MATERIALS (1)

No.	PART	CV 41-DI (3)
1	Body	Ductile Iron ASTM A536
2	Seat (2)	Buna-N, Viton, or EPDM
3	Disc	Bronze or Series 300 Stainless Steel
4	Spring (2)	Series 300 Stainless Steel
5	Shaft/Stop Pin	Series 300 Stainless Steel
6	NPT Plug	Commercial Steel
7	Eye Bolt (4)	Commercial Steel

1. Bill of Materials represents standard materials. Equivalent or better materials may be substituted at the manufacturer's discretion.
2. Denotes recommended spare parts.
3. Ductile Iron bodies are epoxy painted.
4. Eye Bolt is available on larger sizes only.

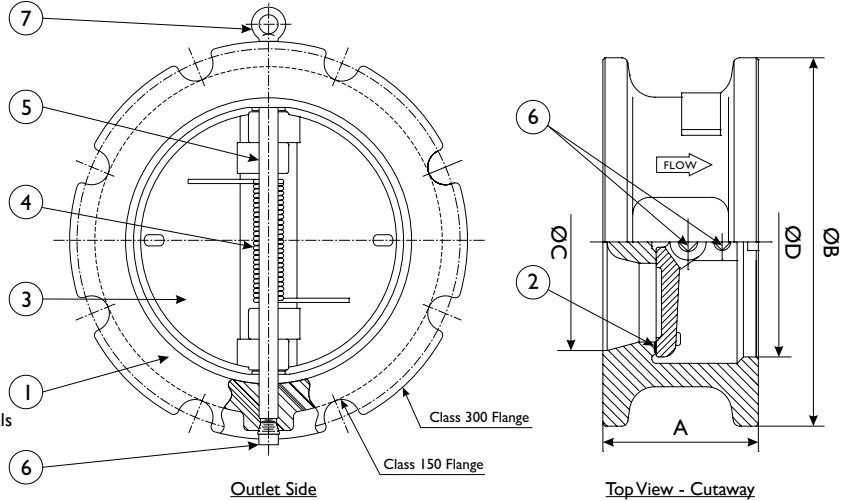

CAD illustration is representative of sizes 2" through 6". Sizes 8" through 24" are not scalloped. Sizes 2" through 6" are designed for dual pressure service (ANSI Class 150 and 300).

Ductile Iron Application Notes:

Ductile Iron maintains the anti-corrosive properties of Cast Iron while achieving a yield strength comparable to Carbon Steel. Ductile Iron also offers higher pressure/temperature ratings than Cast Iron. For example, Ductile Iron check valves (class 300 - sizes 2" ~ 24") are rated at 640 psi wog. By comparison, Cast Iron check valves (class 250 - sizes 2" ~ 12") are rated at 500 psi wog and (sizes 14" ~ 24") are only rated at 300 psi wog. Ductile Iron ANSI Classes 150 and 300 have the same bolting pattern as Cast Iron ANSI Classes 125 and 250 respectively.

DIMENSIONS AND PERFORMANCE DATA (1)

SIZE	DIMENSIONS AND PERFORMANCE DATA (1)															
	in	2	2 1/2	3	4	5	6	8	10	12	14	16	18	20	24	
A DIMENSION FACE TO FACE (2)	mm	50	65	80	100	125	150	200	250	300	350	400	450	500	600	
ØB DIMENSION OUTLET OUTSIDE DIA.	in	2.12	2.12	2.25	2.50	2.75	3.00	3.75	4.25	5.62	7.25	7.50	8.00	8.37	8.75	
ØC DIMENSION INLET INSIDE DIA.	in	4.37	5.12	5.75	7.12	8.50	9.87	11.00	13.37	16.12	17.75	20.25	21.62	23.87	28.25	
ØD DIMENSION OUTLET INSIDE DIA.	in	1.11	1.31	1.46	1.81	2.16	2.51	2.80	3.40	4.10	4.51	5.15	5.50	6.07	7.18	
ASSEMBLED WEIGHT	in	2.00	2.50	3.00	4.00	5.00	6.00	8.00	10.00	12.00	14.00	16.00	18.00	20.00	24.00	
Flow Coefficient	mm	51	64	77	102	127	153	204	254	305	356	407	458	508	610	
Cracking Pressure (3)	in	2.62	3.12	3.87	4.75	6.00	7.00	9.00	11.00	13.25	14.25	16.25	18.12	20.12	24.00	
	mm	67	80	98	121	152	178	229	280	337	362	413	461	512	610	
	lb	4.0	5.0	7.0	14.0	18.0	26.5	43.0	70.0	108.0	175.0	200.0	258.0	345.0	460.0	
	kg	1.8	2.3	3.2	6.3	8.2	12.0	19.5	31.7	48.9	79.4	90.7	117.0	156.5	208.7	
	psi	62	110	175	350	550	850	1500	2400	3700	5400	8250	10400	14200	23000	
	psi	≤ .25	≤ .25	≤ .25	≤ .25	≤ .25	≤ .25	≤ .25	≤ .25	≤ .25	≤ .25	≤ .25	≤ .25	≤ .25	≤ .25	

1. Dimensions and weights are for reference only. When required, request certified drawings.
2. Face to face values have a tolerance of ±0.06 in (±2.0 mm) for sizes 10" and lower and a tolerance of ±0.12 in (±3.0 mm) for sizes 12" and larger.
3. Cracking pressure is for horizontal installations only. For vertical installations, please consult factory.

PRESSURE - TEMPERATURE RATINGS (1)

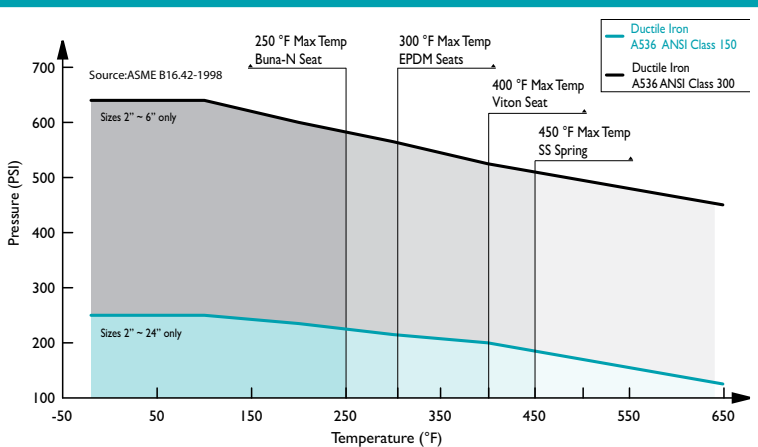

1. The above chart displays the pressure-temperature ratings for the valve's body material per ASME B16.42-1998. Max temperature limits have been added for seat and spring materials. Sizes 2" through 6" are dual pressure rated for both ANSI Class 150 and 300.

Titan FCI makes every effort to ensure the information presented on our literature accurately reflects exact product specifications. However, as product changes occur, there may be short-term differences between actual product specifications and the information contained within our literature. Titan FCI reserves the right to make design and specification changes to improve our products without prior notification. When required, request certified drawings.

REFERENCED STANDARDS & CODES

CODE	DESCRIPTION
ANSI/API 594	Valve Design and Manufacture
ASME/ANSI 16.5	Flange Dimensions
ASME/ANSI B16.34	Valves - Flanged, Threaded, and Welding End
ANSI/API 594	Valve Face to Face Dimensions
ASME/ANSI B16.42	Ductile Iron Pipe Flanges and Flanged Fittings
API 598	Valve Inspection and Pressure Test

PRESSURE / TEMPERATURE RATING - ASTM A536

Body Material	Class 150 (2" ~ 24")	Class 300 (2" ~ 6")
WOG (Non-shock):	250 PSI @ 100 °F	640 PSI @ 100 °F

SEAT AND SPRING TEMPERATURE RATING

Seat Material	Range	Spring Material	Max
EPDM:	-30 ~ 300 °F	Series 300 Stainless Steel:	450 °F
BUNA-N:	-20 ~ 250 °F		
VITON:	-40 ~ 400 °F		