



TITAN FLOW CONTROL, INC.

## SILENT CHECK VALVE ♦ GLOBE TYPE ♦ CENTER GUIDED

### ANSI CLASS 150 ♦ DUCTILE IRON ♦ FLANGED ENDS, FLAT FACE

# MODEL: CV 50-DI

Body: Ductile Iron

Trim: Stainless Steel &amp; Bronze

PATENT-PENDING  
DESIGN WITH INTEGRAL  
STRAIGHTENING  
VANES



### SIZE RANGE: 2" ~ 24"

LARGER SIZES AVAILABLE

## FEATURES

#### ◆ DESIGNED FOR LONG SERVICE LIFE

NEWLY DESIGNED CV50'S HAVE STRAIGHTENING VANES THAT REDUCE TURBULENCE IN INCOMING FLOW, THUS MINIMIZING NOISE, VIBRATIONS, EROSION, CAVITATIONS, AND OTHER FACTORS THAT COULD RESULT IN PREMATURE VALVE FAILURE.

#### ◆ MINIMAL HEAD LOSS

HEAD LOSS IS MINIMIZED BY THE INTEGRAL STRAIGHTENING VANES THAT HELP CREATE LAMINAR FLOW. A LARGE CROSS-SECTIONAL AREA ALSO LESSENS PRESSURE DROP ACROSS THE CHECK VALVE. UNLIKE TYPICAL CONICAL SPRING CONSTRUCTIONS THAT RESTRICT FLOW, THE NEW CV 50 HAS A COMPRESSION SPRING COUPLED WITH A SMALL STEM GUIDE THAT ALLOWS FOR AN UNOBSTRUCTED FLOW PATH.

#### ◆ QUICK CLOSURE TO REDUCE WATER HAMMER

SILENT SHUT-OFF IS ACHIEVED VIA THE FULLY AUTOMATIC, SPRING ASSISTED DISC THAT CLOSES NEAR ZERO FLOW VELOCITY. THE LIGHTWEIGHT, CENTER GUIDED DISC DESIGN CREATES A POSITIVE SHUTOFF PRIOR TO FLOW REVERSAL AND HELPS TO KEEP SLAMMING AND SURGES TO A MINIMUM. ADDITIONALLY, THE LOW CRACKING PRESSURE OF THE CV 50 REDUCES THE AMOUNT OF ENERGY REQUIRED TO OPEN THE VALVE.

#### ◆ METAL-TO-METAL SEATS

PRECISION MACHINED SEALING SURFACES ALLOW THE CV 50-DI TO MAINTAIN A TIGHT SEAL THAT MEETS OR EXCEEDS API 598 LEAKAGE REQUIREMENTS. RESILIENT SEATS ARE ALSO AVAILABLE TO PROVIDE BUBBLE TIGHT SEALS. SEALING IS FURTHER IMPROVED BY AN ADDITIONAL GASKET ASSEMBLED WITH THE SEAT INDEPENDENT OF THE FLANGE GASKET.

#### ◆ VERSATILE AND ECONOMIC DESIGN

CLEARANCE WITHIN THE CV 50'S BODY ALLOWS A BUTTERFLY VALVE TO BE INSTALLED DIRECTLY ON THE OUTLET SIDE OF THE VALVE WITHOUT EXTRA PIPING. BECAUSE THE VALVE'S TRIM IS INTERCHANGEABLE, VARIOUS SEATS, DISCS, AND SPRINGS ARE AVAILABLE AND EASY TO REPLACE. EXOTIC SPRING MATERIAL, SUCH AS MONEL OR INCONEL 750-X, CAN EASILY BE SUBSTITUTED FOR THE STANDARD STAINLESS STEEL

## TECHNICAL

PRESSURE/TEMPERATURE RATING <sup>(1)</sup>  
DUCTILE IRON - ASTM A536 - CLASS 150

WOG (Non-Shock): 250 PSI @ 100 °F

SEAT MATERIAL  
TEMPERATURE RANGE

ALUMINUM BRONZE: -460 ~ 600 °F  
STAINLESS STEEL: -325 ~ 1500 °F

SPRING MATERIAL  
MAXIMUM TEMPERATURE

STAINLESS STEEL: 450 °F

1. The above listed temperatures are theoretical and may vary during actual operating conditions.

## APPLICATIONS

**MARKETS:** OIL AND GAS PRODUCTION, GENERAL INDUSTRY, CHEMICAL, PETROCHEMICAL, POWER, FOOD AND BEVERAGE

**SERVICE:** PUMP DISCHARGE SERVICE IN MUNICIPAL WATER, IRRIGATION, AND INDUSTRIAL CLASS HVAC SYSTEMS. IT IS RECOMMENDED THAT A TITAN FCI STRAINER BE INSTALLED AHEAD OF THE PUMP TO ENSURE PROTECTION OF THE CHECK VALVE AND THE PUMP.

**PRECAUTIONS:** THIS VALVE IS INTENDED FOR LIQUID SERVICE THAT DOES NOT EXCEED 10 FT/SEC. IT IS DESIGNED FOR STEADY FLOW CONDITIONS AND IS NOT RECOMMENDED FOR USE IN RECIPROCATING PUMP, COMPRESSOR OR OTHER TYPE OF PHYSICAL/THERMAL SHOCK-LOAD APPLICATIONS. THIS VALVE IS NOT RECOMMENDED FOR STEAM SERVICE OR FLOW MEDIA THAT CONTAINS SOLIDS. IT SHOULD BE INSTALLED AT LEAST FIVE PIPE DIAMETERS DOWNSTREAM FROM ANY TURBULENCE PRODUCING COMPONENTS. FLOW STRAIGHTENERS MAY BE REQUIRED IN CERTAIN APPLICATIONS.

The above data represents common market and service applications. No representation or guarantee, expressed or implied, is given due to the numerous variations of concentrations, temperatures and flow conditions that may occur during actual service.

# TITAN FLOW CONTROL, INC.

YOUR PIPELINE TO THE FUTURE!

Tel: 910-735-0000 ♦ Fax: 910-738-3848 ♦ titan@titanfci.com ♦ www.titanfci.com  
290 Corporate Drive ♦ PO Box 7408 ♦ Lumberton, NC 28358



**TITAN FLOW CONTROL, Inc.**

290 Corporate Drive  
Lumberton, NC 28358  
Tel: 910.735.0000

E-mail: titan@titanfci.com  
Web: www.titanfci.com  
Fax: 910.738.3848

**SILENT CHECK VALVE • GLOBE TYPE**

**CV 50-DI (Ductile Iron)**

ANSI Class  
150 lb

Flanged Ends, Flat Faced • Globe Style • Center Guided Disc

**BILL OF MATERIALS (1)**

No.	PART	CV 50-DI-B	CV 50-DI-S
1	Body	Ductile Iron ASTM A536	Ductile Iron ASTM A536
2	Disc (2)	Aluminum Bronze ASTM B148	Stainless Steel Gr. CF8M Type 316 SS
3	Spring (2)	Series 300 Stainless Steel	Series 300 Stainless Steel
4	Bushing (2)	Aluminum Bronze	Stainless Steel
5	Seat (2) (3)	Aluminum Bronze ASTM B148	Stainless Steel Gr. CF8M Type 316 SS
6	Cap Screw	Stainless Steel	Stainless Steel
7	Gasket	Non-asbestos Gasket	Non-asbestos Gasket

1. Bill of Materials represents standard materials. Equivalent or better materials may be substituted at the manufacturer's discretion.
2. Denotes recommended spare parts.
3. Resilient Seats are available upon request. Please call for details.

**Additional Design & Technical Notes:**

- The CV 50-DI is designed to fit Cast Iron Class 125 and Ductile Iron Class 150 Flanges. The bolting pattern for Cast Iron Class 125 and Ductile Iron Class 150 are identical.
- Ductile Iron maintains the anti-corrosive properties of Cast Iron while achieving a yield strength comparable to Carbon Steel. It also offers higher pressure/temp ratings than Cast Iron.
- All CV 50-DI valve bodies are epoxy painted.

Illustrations are for representational purposes only.  
Please ask for certified drawings when necessary.

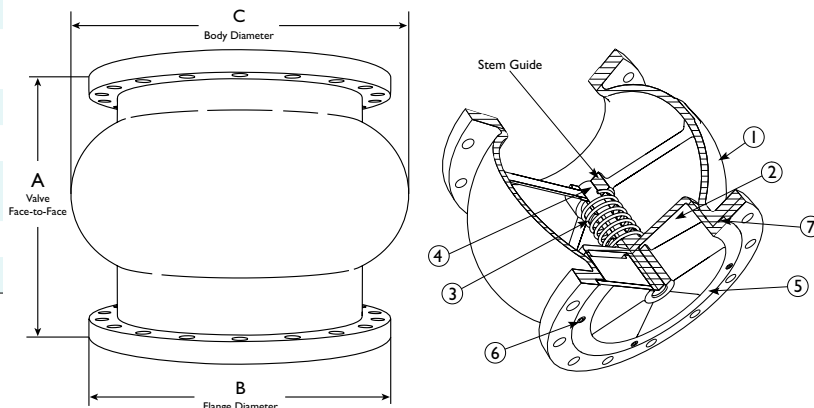

**DIMENSIONS AND PERFORMANCE DATA (1)**

SIZE	in	2	2 1/2	3	4	5	6	8	10	12	14	16	18	20	24
	mm	50	65	80	100	125	150	200	250	300	350	400	450	500	600
A DIMENSION FACE TO FACE (2)	in	6.25	7.00	7.50	8.50	9.50	10.50	13.50	16.25	20.25	22.75	24.75	22.50	24.00	24.00
	mm	159	178	191	216	241	267	343	413	514	578	629	572	610	610
ØB DIMENSION FLANGE DIAMETER	in	6.00	7.00	7.50	9.00	10.00	11.00	13.50	16.00	19.00	21.00	23.50	25.00	27.50	32.00
	mm	153	178	191	229	254	280	343	406	483	533	597	635	699	813
ØC DIMENSION BODY DIAMETER	in	4.625	5.75	6.625	8.625	10.00	11.125	15.84	17.687	21.25	23.95	25.875	29.0	32.75	36.96
	mm	117	146	168	219	254	283	402	449	540	608	657	737	832	939
WEIGHT (APPROXIMATE)	lb	14.0	24.0	27.5	44.0	C/F	83.0	145.0	220.0	344.0	453.5	593.0	695.5	963.0	C/F
	kg	6.4	10.9	12.5	20.0	C/F	37.6	65.8	99.8	156.0	205.7	269.0	315.5	436.8	C/F
Flow Coefficient	C <sub>v</sub>	65	105	150	265	410	600	1100	1800	2500	3100	4300	5000	6300	9800
Cracking Pressure (3)	psi	≤ .5	≤ .5	≤ .5	≤ .5	≤ .5	≤ .5	≤ .5	≤ .5	≤ .5	≤ .5	≤ .5	≤ .5	≤ .5	≤ .5

1. Dimensions, weights, and flow coefficients are provided for reference only. When required, always request certified drawings.
2. Face to face values have a tolerance of ±0.06 in (±2.0 mm) for sizes 10" and lower and a tolerance of ±0.12 in (±3.0 mm) for sizes 12" and larger.
3. Cracking pressure is for horizontal installations only. For vertical installations, please consult factory.

**PRESSURE - TEMPERATURE RATINGS (1)**

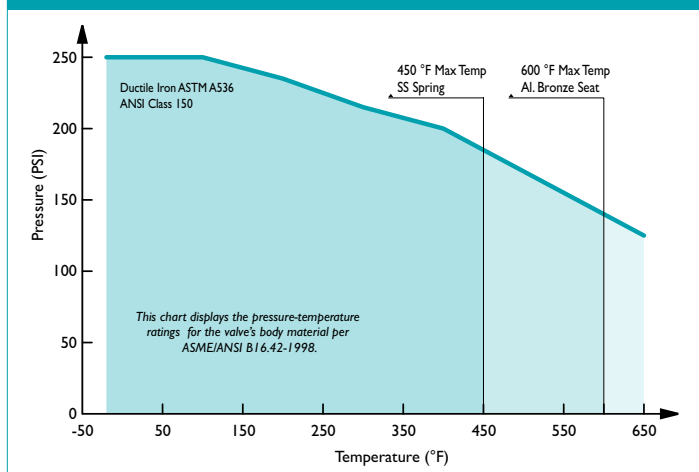

1. This chart displays the pressure-temperature ratings for the valve's body. Max temperature limits have been added for seat and spring materials.

**ORDERING CODE**

Model Number	Description
CV50-DI-B	Ductile Iron Body, Bronze Seat and Disc
CV50-DI-S	Ductile Iron Body, Stainless Steel Seat and Disc

**REFERENCED STANDARDS & CODES**

CODE	DESCRIPTION
ANSI B16.42	Ductile Iron Pipe Flanges and Flanged Fittings
ANSI B16.5	Pipe Flanges & Flanged Fittings
MSS SP-6	Standard Finishes for Connecting-end Flanges
MSS SP-25	Standard Marking System for Valves
MSS SP-55	Quality Standard for Valve Castings

**PRESSURE - TEMPERATURE RATING**

<b>ANSI CLASS 150</b>	ASTM A536
WOG (Non-Shock)	250 PSI @ 100 °F

**TEMPERATURE RANGE SEAT**

SEAT	Temperature
Aluminum Bronze	-460 °F @ 600 °F
Stainless Steel	-325 ~ 1500 °F

**MAX TEMPERATURE SPRING**

SPRING	Max Temperature
Stainless Steel	450 °F

The listed pressure and temperature ratings for the valve's body, seat, and spring are theoretical and may vary during actual operating conditions.

Titan FCI makes every effort to ensure the information presented on our literature accurately reflects exact product specifications. However, as product changes occur, there may be short-term differences between actual product specifications and the information contained within our literature. Titan FCI reserves the right to make design and specification changes to improve our products without prior notification. When required, request certified drawings.