



TITAN FLOW CONTROL, INC.

SILENT CHECK VALVE ♦ GLOBE TYPE ♦ CENTER GUIDED

ANSI CLASS 300 ♦ CARBON & STAINLESS STEEL ♦ FLANGED ENDS (RF)

MODELS: CV 52-CS CV 52-SS

Body: Carbon & Stainless Steel
Trim: Stainless Steel

PATENT-PENDING
DESIGN WITH INTEGRAL
STRAIGHTENING
VANES



FEATURES

SIZE RANGE: 2" ~ 14"

LARGER SIZES AVAILABLE

◆ DESIGNED FOR LONG SERVICE LIFE

NEWLY DESIGNED CV52'S HAVE STRAIGHTENING VANES THAT REDUCE TURBULENCE IN INCOMING FLOW, THUS MINIMIZING NOISE, VIBRATIONS, EROSION, CAVITATIONS, AND OTHER FACTORS THAT COULD RESULT IN PREMATURE VALVE FAILURE.

◆ MINIMAL HEAD LOSS

HEAD LOSS IS MINIMIZED BY THE INTEGRAL STRAIGHTENING VANES THAT HELP CREATE LAMINAR FLOW. A LARGE CROSS-SECTIONAL AREA ALSO LESSENS PRESSURE DROP ACROSS THE CHECK VALVE. UNLIKE TYPICAL CONICAL SPRING CONSTRUCTIONS THAT RESTRICT FLOW, THE NEW CV 52 HAS A COMPRESSION SPRING COUPLED WITH A SMALL STEM GUIDE THAT ALLOWS FOR AN UNOBSTRUCTED FLOW PATH.

◆ QUICK CLOSURE TO REDUCE WATER HAMMER

SILENT SHUTOFF IS ACHIEVED VIA THE FULLY AUTOMATIC, SPRING ASSISTED DISC THAT CLOSES NEAR ZERO FLOW VELOCITY. THE LIGHTWEIGHT, CENTER GUIDED DISC DESIGN CREATES A POSITIVE SHUTOFF PRIOR TO FLOW REVERSAL AND HELPS TO KEEP SLAMMING AND SURGES TO A MINIMUM. ADDITIONALLY, THE LOW CRACKING PRESSURE OF THE CV 52 REDUCES THE AMOUNT OF ENERGY REQUIRED TO OPEN THE VALVE.

◆ METAL-TO-METAL SEATS

PRECISION MACHINED SEALING SURFACES ALLOW THE CV 52-CS/SS TO MAINTAIN A TIGHT SEAL THAT MEETS OR EXCEEDS API 598 LEAKAGE REQUIREMENTS. RESILIENT SEATS ARE ALSO AVAILABLE TO PROVIDE BUBBLE TIGHT SEALS. SEALING IS FURTHER IMPROVED BY AN ADDITIONAL GASKET ASSEMBLED WITH THE SEAT INDEPENDENT OF THE FLANGE GASKET.

◆ VERSATILE AND ECONOMIC DESIGN

CLEARANCE WITHIN THE CV 52'S BODY ALLOWS A BUTTERFLY VALVE TO BE INSTALLED DIRECTLY ON THE OUTLET SIDE OF THE VALVE WITHOUT EXTRA PIPING. BECAUSE THE VALVE'S TRIM IS INTERCHANGEABLE, VARIOUS SEATS, DISCS, AND SPRINGS ARE AVAILABLE AND EASY TO REPLACE. EXOTIC SPRING MATERIAL, SUCH AS MONEL OR INCONEL 750-X, CAN BE SUBSTITUTED EASILY FOR THE STANDARD STAINLESS STEEL.

TECHNICAL

PRESSURE/TEMPERATURE RATING ⁽¹⁾
CS - ASTM A216 Gr. WCB - CLASS 300

WOG (Non-shock): 740 PSI @ 100 °F

PRESSURE/TEMPERATURE RATING ⁽¹⁾
SS - ASTM A351 Gr. CF8M - CLASS 300

WOG (Non-shock): 720 PSI @ 100 °F

SEAT MATERIAL ⁽¹⁾
TEMPERATURE RANGE

STAINLESS STEEL: -325 ~ 1500 °F

SPRING MATERIAL ⁽¹⁾
MAXIMUM TEMPERATURE

STAINLESS STEEL: 450 °F

1. The above listed temperatures are theoretical and may vary during actual operating conditions.

APPLICATIONS

MARKETS: OIL AND GAS PRODUCTION, GENERAL INDUSTRY, CHEMICAL, PETROCHEMICAL, POWER, FOOD AND BEVERAGE

SERVICE: PUMP DISCHARGE SERVICE IN MUNICIPAL WATER, IRRIGATION, AND INDUSTRIAL CLASS HVAC SYSTEMS. IT IS RECOMMENDED THAT A TITAN FCI STRAINER BE INSTALLED AHEAD OF THE PUMP TO ENSURE PROTECTION OF THE CHECK VALVE AND THE PUMP.

PRECAUTIONS: THIS VALVE IS INTENDED FOR LIQUID SERVICE THAT DOES NOT EXCEED 10 FT/SEC. IT IS DESIGNED FOR STEADY FLOW CONDITIONS AND IS NOT RECOMMENDED FOR USE IN RECIPROCATING PUMP, COMPRESSOR OR OTHER TYPE OF PHYSICAL/THERMAL SHOCK-LOAD APPLICATIONS. THIS VALVE IS NOT RECOMMENDED FOR STEAM SERVICE OR FLOW MEDIA THAT CONTAINS SOLIDS. IT SHOULD BE INSTALLED AT LEAST FIVE PIPE DIAMETERS DOWNSTREAM FROM ANY TURBULENCE PRODUCING COMPONENTS. ADDITIONAL FLOW STRAIGHTENERS MAY BE REQUIRED IN CERTAIN APPLICATIONS.

The above data represents common market and service applications. No representation or guarantee, expressed or implied, is given due to the numerous variations of concentrations, temperatures and flow conditions that may occur during actual service.

TITAN FLOW CONTROL, INC.

YOUR PIPELINE TO THE FUTURE!

Tel: 910-735-0000 ♦ Fax: 910-738-3848 ♦ titan@titanfci.com ♦ www.titanfci.com
290 Corporate Drive ♦ PO Box 7408 ♦ Lumberton, NC 28358



TITAN FLOW CONTROL, Inc.

290 Corporate Drive
Lumberton, NC 28358
Tel: 910.735.0000

E-mail: titan@titanfci.com
Web: www.titanfci.com
Fax: 910.738.3848

SILENT CHECK VALVE • GLOBE TYPE
CV 52-CS (Carbon) CV 52-SS (Stainless Steel)

ANSI Class
300

Flanged Ends (RF) • Globe Style • Center Guided Disc

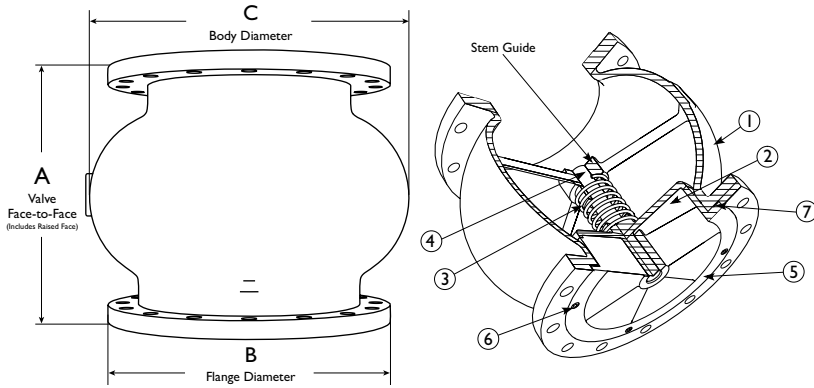

Additional Notes:

- Face-to-Face Dimension 'A' *includes* raised face. Class 300 flanges are regularly furnished with 1/16 inch high raised face.
- Carbon Steel bodies are epoxy painted. Other coatings are available, please contact factory for details.

BILL OF MATERIALS ⁽¹⁾			
No.	PART	CV 52-CS	CV 52-SS
1	Body	Carbon Steel A216 Gr. WCB	Stainless Steel A351 Gr. CF8M Type 316
2	Disc ⁽²⁾	Stainless Steel Gr. CF8M Type 316	Stainless Steel A351 Gr. CF8M Type 316
3	Spring ⁽²⁾	Series 300 Stainless Steel	Series 300 Stainless Steel
4	Bushing ⁽²⁾	Stainless Steel	Stainless Steel
5	Seat ^{(2),(3)}	Stainless Steel A351 Gr. CF8M Type 316	Stainless Steel A351 Gr. CF8M Type 316
6	Cap Screw	Stainless Steel	Stainless Steel
7	Gasket ⁽²⁾	Non-asbestos Gasket	Non-asbestos Gasket

1. Bill of Materials represents standard materials. Equivalent or better materials may be substituted at the manufacturer's discretion.
2. Denotes recommended spare parts.
3. Resilient Seats are available upon request. Please call for details.

DIMENSIONS AND PERFORMANCE DATA ⁽¹⁾											
SIZE ⁽²⁾	in	2	2 1/2	3	4	5	6	8	10	12	14
	mm	50	65	80	100	125	150	200	250	300	350
A DIMENSION FACE TO FACE ⁽³⁾	in	6.69	7.56	8.25	9.12	C/F	11.38	13.0	15.38	19.5	21.0
	mm	170	192	210	232	C/F	289	330	391	495	533
ØB DIMENSION FLANGE DIAMETER	in	6.50	7.50	8.25	10.0	C/F	12.5	15.0	17.5	20.5	23.0
	mm	165	191	210	254	C/F	318	381	445	521	584
ØC DIMENSION BODY DIAMETER	in	4.63	5.75	6.63	8.62	C/F	11.13	15.84	17.69	21.5	24.0
	mm	118	146	168	219	C/F	283	402	449	546	610
WEIGHT (APPROXIMATE)	lb	18.0	26.0	38.5	61.0	C/F	109.0	196.0	272.0	430.0	560.5
	kg	8.2	11.8	17.5	27.7	C/F	49.4	88.9	123.4	195.0	254.2
Flow Coefficient	C _v	65	105	150	265	410	600	1100	1800	2500	3100
Cracking Pressure ⁽⁴⁾	psi	≤ .5	≤ .5	≤ .5	≤ .5	≤ .5	≤ .5	≤ .5	≤ .5	≤ .5	≤ .5

1. Dimensions, weights, and flow coefficients are provided for reference only. When required, always request certified drawings.
2. Larger sizes are available. Please consult factory for these sizes and dimensions.
3. Face to face values have a tolerance of ±0.06 in (±2.0 mm) for sizes 10" and lower and a tolerance of ±0.12 in (±3.0 mm) for sizes 12" and larger.
4. Cracking pressure is for horizontal installations only. For vertical installations, please consult factory.

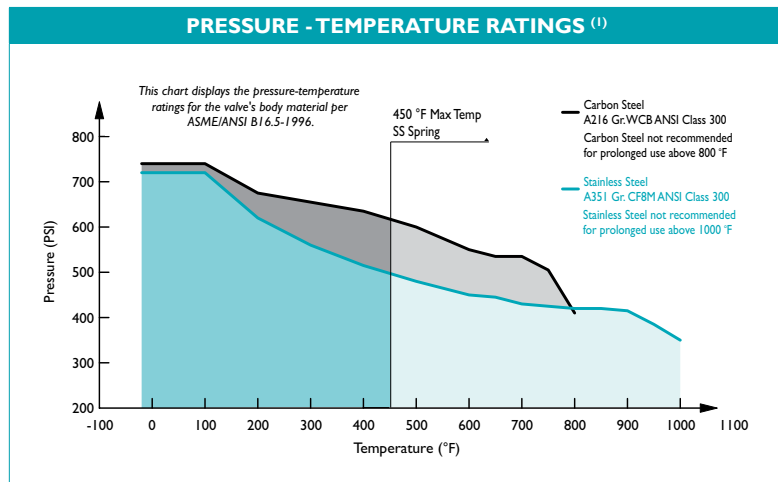

1. This chart displays the pressure-temperature ratings for the valve's body. Max temperature limits have been added for the spring material.

ORDERING CODE	
Model Number	Description
CV52-CS	Carbon Steel Body, Stainless Steel Seat and Disc
CV52-SS	Stainless Steel Body, Stainless Steel Seat and Disc

REFERENCED STANDARDS & CODES	
CODE	DESCRIPTION
ANSI B16.5	Pipe Flanges & Flanged Fittings
ANSI/API 594	Valve Design and Manufacture
API 598	Valve Inspection and Pressure Test
MSS SP-6	Standard Finishes for Connecting-end Flanges
MSS SP-25	Standard Marking System for Valves
MSS SP-55	Quality Standard for Valve Castings

PRESSURE - TEMPERATURE RATING		
ANSI CLASS 300	Carbon Steel	Stainless Steel
WOG (Non-shock)	740 PSI @ 100 °F	720 PSI @ 100 °F

TEMPERATURE RANGE SEAT	
SEAT	Temperature
Stainless Steel	-325 ~ 1500 °F

MAX TEMPERATURE SPRING	
SPRING	Max Temperature
Stainless Steel	450 °F

The listed pressure and temperature ratings for the valve's body, seat, and spring are theoretical and may vary during actual operating conditions.

Titan FCI makes every effort to ensure the information presented on our literature accurately reflects exact product specifications. However, as product changes occur, there may be short-term differences between actual product specifications and the information contained within our literature. Titan FCI reserves the right to make design and specification changes to improve our products without prior notification. When required, request certified drawings.