



TITAN FLOW CONTROL, INC.

MINI-CHECK VALVE ♦ FLANGED ♦ CENTER GUIDED

ANSI CLASS 150 / 300 ♦ STAINLESS STEEL BODY

MODEL: CV 70-SS
(STAINLESS STEEL)

SIZE RANGE: 1/2" ~ 3"

All sizes provide
Dual Pressure Service
ANSI Class 150/300

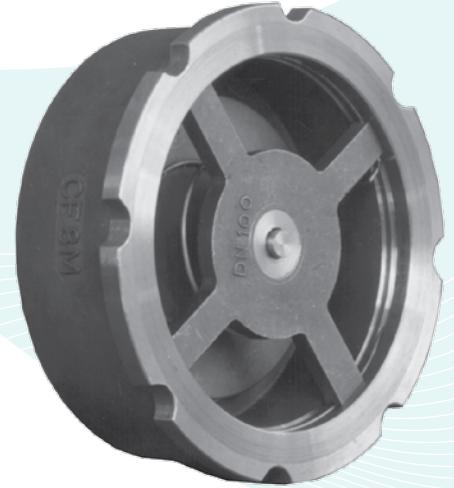

FEATURES

- ♦ **DESIGNED FOR LONG SERVICE LIFE**
THE CV 70'S STAINLESS STEEL BODY AND TRIM ARE HIGHLY CORROSION RESISTANT, EXTREMELY STRONG, AND WELL SUITED FOR HIGH TEMPERATURE APPLICATIONS - UP TO 1000°F IN CONTINUOUS SERVICE.
- ♦ **MINIMAL HEAD LOSS**
THE SPRING-LOADED, CENTER GUIDED DISC IS DESIGNED WITH VERY LOW CRACKING PRESSURE WHICH REDUCES THE AMOUNT OF ENERGY REQUIRED TO OPEN THE VALVE.
- ♦ **QUICK CLOSURE TO REDUCE WATER HAMMER**
SILENT SHUT-OFF IS ACHIEVED VIA THE FULLY AUTOMATIC, SPRING ASSISTED DISC THAT CLOSES NEAR ZERO FLOW VELOCITY. THE LIGHTWEIGHT, CENTER GUIDED DISC DESIGN CREATES A POSITIVE SHUTOFF PRIOR TO FLOW REVERSAL AND HELPS TO KEEP SLAMMING AND SURGES TO A MINIMUM.
- ♦ **METAL-TO-METAL SEATS**
PRECISION MACHINED SEALING SURFACES ALLOW THE CV 70-SS TO MAINTAIN A TIGHT SEAL THAT MEETS OR EXCEEDS API 598 LEAKAGE REQUIREMENTS.
- ♦ **VERSATILE DESIGN**
THE CV 70 HAS A UNIQUE SCALLOP DESIGN. IT WILL FIT BETWEEN ANY ANSI CLASS 125, ANSI CLASS 250, ANSI CLASS 150, AND ANSI CLASS 300 FLANGES IN A SINGLE FLANGE-SUPPORTED INSTALLATION.

TECHNICAL

PRESSURE/TEMPERATURE RATING
STAINLESS STEEL - ASTM A351 GR. CF8M - CLASS 150

WOG (Non-shock): 275 PSI @ 100 °F

PRESSURE/TEMPERATURE RATING
STAINLESS STEEL - ASTM A351 GR. CF8M - CLASS 300

WOG (Non-shock): 720 PSI @ 100 °F

SEAT MATERIAL
TEMPERATURE RANGE

STAINLESS STEEL: -325 ~1500 °F

SPRING MATERIAL
MAXIMUM TEMPERATURE

STAINLESS STEEL: 450 °F
INCONEL (only if specified): 1000 °F

- The above listed temperatures are theoretical and may vary during actual operating conditions.
- Stainless Steel is not recommended for prolonged use above 1000 °F.

APPLICATIONS

MARKETS: GENERAL INDUSTRY, CHEMICAL, PETROCHEMICAL, PHARMACEUTICAL, STEAM, MARINE, AND HIGH TEMPERATURE

SERVICE: PUMP DISCHARGE SERVICE IN MUNICIPAL WATER, IRRIGATION, AND INDUSTRIAL CLASS HVAC SYSTEMS. IT IS RECOMMENDED THAT A TITAN FCI STRAINER BE INSTALLED AHEAD OF THE PUMP TO ENSURE PROTECTION OF THE CHECK VALVE AND THE PUMP.

PRECAUTIONS: THIS VALVE IS INTENDED FOR LIQUID SERVICE THAT DOES NOT EXCEED 10 FT/SEC. IT IS DESIGNED FOR STEADY FLOW CONDITIONS AND IS NOT RECOMMENDED FOR USE IN RECIPROCATING PUMP, COMPRESSOR OR OTHER TYPE OF PHYSICAL/THERMAL SHOCK-LOAD APPLICATIONS. THIS VALVE IS NOT RECOMMENDED FOR STEAM SERVICE OR FLOW MEDIA THAT CONTAINS SOLIDS. IT SHOULD BE INSTALLED AT LEAST FIVE PIPE DIAMETERS DOWNSTREAM FROM ANY TURBULENCE PRODUCING COMPONENTS. FLOW STRAIGHTENERS MAY BE REQUIRED IN CERTAIN APPLICATIONS.

The above data represents common market and service applications. No representation or guarantee, expressed or implied, is given due to the numerous variations of concentrations, temperatures and flow conditions that may occur during actual service.

TITAN FLOW CONTROL, INC.
YOUR PIPELINE TO THE FUTURE!

Tel: 910-735-0000 ♦ Fax: 910-738-3848 ♦ titan@titanfci.com ♦ www.titanfci.com
290 Corporate Drive ♦ PO Box 7408 ♦ Lumberton, NC 28358

TITAN FLOW CONTROL, Inc.

 290 Corporate Drive
 Lumberton, NC 28358
 Tel: 910.735.0000

 E-mail: titan@titanfci.com
 Web: www.titanfci.com
 Fax: 910.738.3848

FLANGED MINI-CHECK VALVE • WAFER TYPE
CV 70-SS - (Stainless Steel)
Wafer Type • Stainless Steel Body • Center Guided Disk
ANSI Class
150/300
BILL OF MATERIALS ⁽¹⁾

No.	PART	CV 70-SS
1	Body	Stainless Steel A351 Gr. CF8M
2	Yoke	Stainless Steel A351 Gr. CF8M
3	Spring ⁽²⁾	Series 300 Stainless Steel
4	Disc	Stainless Steel A351 Gr. CF8M
5	Seat	Stainless Steel ⁽³⁾ A351 Gr. CF8M
6	Circlip	Series 300 Stainless Steel

1. Bill of Materials represents standard materials. Equivalent or better materials may be substituted at the manufacturer's discretion.
2. Denotes recommended spare parts.
3. Resilient, soft seats are also available -- Please consult factory.

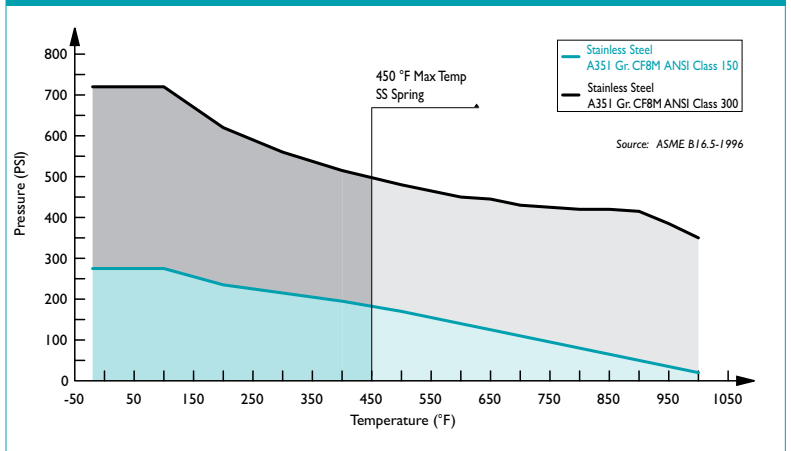
PRESSURE - TEMPERATURE RATINGS

1. The above chart displays the pressure-temperature ratings for the valve's body material per ASME B16.5-1996. Max temperature limits have been added for the spring material.

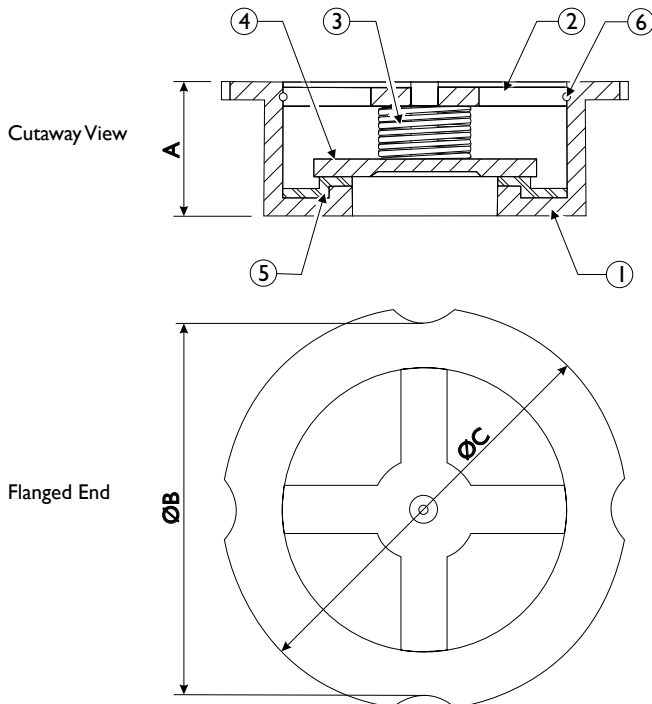

Illustrations are representative of sizes 1/2" through 3".
 Please ask for certified drawings when required.

PRESSURE - TEMPERATURE RATING

Body Material	150 lb Service	300 lb Service
WOG (Non-shock):	275 PSI @ 100 °F	720 PSI @ 100 °F

SEAT AND SPRING TEMPERATURE RATINGS ⁽¹⁾

SEAT	Temperature Range
Metal	-325 °F @ 1500 °F
SPRING	Maximum Temperature
Stainless Steel	450 °F
Inconel (only if specified)	1000 °F

1. The listed pressure and temperature ratings for the valve's body, seat, and spring are theoretical and may vary during actual operating conditions.

REFERENCED STANDARDS & CODES

CODE	DESCRIPTION
ASME/ANSI B16.5	Pipe Flanges and Flanged Fittings
MSS SP-6	Standards Finishes for Connecting-end Flanges
MSS SP-25	Standard Marking System for Valves
MSS SP-55	Quality Standard for Valve Castings
MSS SP-126	Steel, In-Line, Spring-Assisted, Center-Guided Valves

DIMENSIONS AND PERFORMANCE DATA ⁽¹⁾

SIZE	in	1/2	3/4	1	1 1/4	1 1/2	2	2 1/2	3
	mm	15	20	25	32	40	50	65	80
A DIMENSION FACE TO FACE	in	0.669	0.787	0.905	1.102	1.102	1.547	1.811	1.968
	mm	17	20	23	28	32	40	46	50
ØB DIMENSION SCALLOP DIAMETER	in	1.692	2.086	2.48	2.992	3.346	3.74	4.528	5.196
	mm	43	53	63	76	85	95	115	132
ØC DIMENSION OUTSIDE DIAMETER	in	1.968	2.362	2.756	3.189	3.583	4.173	4.961	5.551
	mm	50	60	70	81	91	106	126	141
APPROXIMATE ASSEMBLED WEIGHT	lb	0.39	0.44	0.55	1.1	1.54	2.86	3.75	6.17
	kg	0.18	0.2	0.25	0.5	0.7	1.3	1.7	2.8
Flow Coefficient	C _v	8	10	25	33	40	60	70	150
Cracking Pressure ⁽²⁾	psi	≤ .5	≤ .5	≤ .5	≤ .5	≤ .5	≤ .5	≤ .5	≤ .5

1. Dimensions, weights, and flow coefficients are for reference only. When required, request certified drawings.
2. Cracking pressure is for horizontal installations only. For vertical installations, please consult factory.

Titan FCI makes every effort to ensure the information presented on our literature accurately reflects exact product specifications. However, as product changes occur, there may be short-term differences between actual product specifications and the information contained within our literature. Titan FCI reserves the right to make design and specification changes to improve our products without prior notification. When required, request certified drawings.

Additional Design & Technical Notes:

- The CV 70 utilizes a unique scallop design that permits dual pressure service (150/300). These sizes fit properly between any ANSI Class 125/250 or ANSI Class 150/300 flanges. The bolting pattern for ANSI Class 125/250 and ANSI Class 150/300 are the same, respectively.
- This series is available in many optional materials such as Alloy 20 and Monel.
- Valves are for liquid service only. They should be installed at least five pipe diameters downstream from any turbulence producing components.