



TITAN FLOW CONTROL, INC.

## SILENT CHECK VALVE ♦ WAFER TYPE ♦ CENTER GUIDED

### ANSI CLASS 150/300 (125/250) ♦ DUCTILE IRON BODY

# MODEL: CV 90-DI

Body: Ductile Iron  
Trims: Stainless Steel or Bronze  
Seats: Buna and Viton



Size Range: 2" ~ 12"

Sizes 2" ~ 6" provide  
Dual Pressure Service  
ANSI Class 150/300

## FEATURES

- ♦ **DESIGNED FOR LONG SERVICE LIFE**  
DUCTILE IRON BODY MAINTAINS THE ANTI-CORROSIVE PROPERTIES OF CAST IRON WHILE ACHIEVING A YIELD STRENGTH COMPARABLE TO CARBON STEEL. DUCTILE IRON CHECK VALVES ALSO OFFER HIGHER PRESSURE AND TEMPERATURE RATINGS WHEN COMPARED TO CAST IRON CHECK VALVES OF THE SAME CLASS.
- ♦ **MINIMAL HEAD LOSS**  
HEAD LOSS IS MINIMIZED BY PROVIDING A LARGE CROSS-SECTIONAL AREA WHICH EXCEEDS THAT OF THE ADJACENT PIPELINE. ADDITIONALLY, THE SPRING-LOADED, CENTER GUIDED DISC IS DESIGNED WITH VERY LOW CRACKING PRESSURE WHICH REDUCES THE AMOUNT OF ENERGY REQUIRED TO OPEN THE VALVE.
- ♦ **QUICK CLOSURE TO REDUCE WATER HAMMER**  
SILENT SHUT-OFF IS ACHIEVED VIA THE FULLY AUTOMATIC, SPRING ASSISTED DISC THAT CLOSES NEAR ZERO FLOW VELOCITY. THE LIGHTWEIGHT, CENTER GUIDED DISC DESIGN CREATES A POSITIVE SHUTOFF PRIOR TO FLOW REVERSAL AND HELPS TO KEEP SLAMMING AND SURGES TO A MINIMUM.
- ♦ **RESILIENT SOFT SEATS**  
SOFT SEATS (BUNA & VITON) COMBINED WITH PRECISION MACHINED SEALING SURFACES ALLOW THE CV 90-DI TO MAINTAIN A BUBBLE SEAL THAT MEETS API 598 LEAKAGE REQUIREMENTS. METAL SEATS CAN ALSO BE FURNISHED.
- ♦ **VERSATILE DESIGN**  
SIZES 2" THROUGH 6" UTILIZE A UNIQUE SCALLOP DESIGN THAT PERMITS DUAL PRESSURE SERVICE (ANSI CLASS 150 AND 300). SIZES 8" THROUGH 12" ARE ONLY RATED FOR ANSI CLASS 150.

## TECHNICAL

<b>PRESSURE/TEMPERATURE RATING <sup>(1)</sup></b> DUCTILE IRON - ASTM A536 - CLASS 150
WOG (Non-shock): 250 PSI @ 100 °F (2" ~ 12")
<b>PRESSURE/TEMPERATURE RATING <sup>(1)</sup></b> DUCTILE IRON - ASTM A536 - CLASS 300
WOG (Non-shock): 640 PSI @ 100 °F (2" ~ 6")
<b>SEAT MATERIAL (O-RING) <sup>(1)</sup></b> TEMPERATURE RANGE
BUNA-N: -20 ~ 250 °F VITON: -40 ~ 400 °F
<b>SPRING MATERIAL <sup>(1)</sup></b> MAXIMUM TEMPERATURE
STAINLESS STEEL: 450 °F

*1. The above listed temperatures are theoretical and may vary during actual operating conditions.*

## APPLICATIONS

**MARKETS:** OIL AND GAS PRODUCTION, GENERAL INDUSTRY, CHEMICAL, PETROCHEMICAL, POWER, FOOD AND BEVERAGE

**SERVICE:** PUMP DISCHARGE SERVICE IN MUNICIPAL WATER, IRRIGATION, AND INDUSTRIAL CLASS HVAC SYSTEMS. IT IS RECOMMENDED THAT A TITAN FCI STRAINER BE INSTALLED AHEAD OF THE PUMP TO ENSURE PROTECTION OF THE CHECK VALVE AND THE PUMP.

**PRECAUTIONS:** THIS VALVE IS INTENDED FOR LIQUID SERVICE THAT DOES NOT EXCEED 10 FT/SEC. IT IS DESIGNED FOR STEADY FLOW CONDITIONS AND IS NOT RECOMMENDED FOR USE IN RECIPROCATING PUMP, COMPRESSOR OR OTHER TYPE OF PHYSICAL/THERMAL SHOCK-LOAD APPLICATIONS. THIS VALVE IS NOT RECOMMENDED FOR STEAM SERVICE OR FLOW MEDIA THAT CONTAINS SOLIDS. IT SHOULD BE INSTALLED AT LEAST FIVE PIPE DIAMETERS DOWNSTREAM FROM ANY TURBULENCE PRODUCING COMPONENTS. FLOW STRAIGHTENERS MAY BE REQUIRED IN CERTAIN APPLICATIONS.

*The above data represents common market and service applications. No representation or guarantee, expressed or implied, is given due to the numerous variations of concentrations, temperatures and flow conditions that may occur during actual service.*

## TITAN FLOW CONTROL, INC.

YOUR PIPELINE TO THE FUTURE!

Tel: 910-735-0000 ♦ Fax: 910-738-3848 ♦ titan@titanfci.com ♦ www.titanfci.com  
290 Corporate Drive ♦ PO Box 7408 ♦ Lumberton, NC 28358



**TITAN FLOW CONTROL, Inc.**

290 Corporate Drive  
Lumberton, NC 28358  
Tel: 910.735.0000

E-mail: titan@titanfci.com  
Web: www.titanfci.com  
Fax: 910.738.3848

**SILENT CHECK VALVE • WAFER TYPE  
CENTER GUIDED DESIGN • DUCTILE IRON  
MODEL: CV 90-DI - Ductile Iron Body**

**ANSI  
Class  
150/300  
(125/250)**

**BILL OF MATERIALS (1)**

No.	PART	CV 90-DI-B-1
1	Body (2)	ASTM 536 Ductile Iron
2	Seat (3) (4)	Aluminum Bronze with Buna-N O-ring
3	Disc	ASTM B148 Aluminum Bronze
4	Spring (4)	Series 300 Stainless Steel
5	Bushing (4)	Bronze ASTM B584 Copper Alloy 836
6	Screws (4)	ASTM A276 Type 304 Stainless Steel

No.	PART	CV 90-DI-S-3
1	Body (2)	ASTM 536 Ductile Iron
2	Seat (3) (4)	Stainless Steel with Viton O-ring
3	Disc	ASTM A351 Gr. CF8M Type 316 Stainless Steel
4	Spring (4)	Series 300 Stainless Steel
5	Bushing (4)	ASTM A351 Gr. CF8M Type 316 Stainless Steel
6	Screws (4)	ASTM A276 Type 304 Stainless Steel

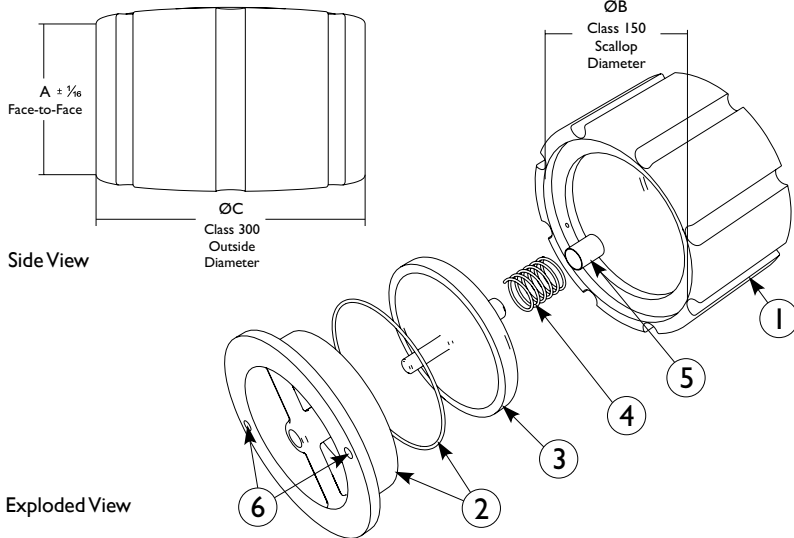

- BOM represents standard materials. Equivalent or better materials may be substituted at the manufacturer's discretion.
- Bodies are epoxy painted.
- Metal seats also available.
- Denotes recommended spare parts.

**Additional Design & Technical Notes:**

Sizes 2" through 6" utilize a unique scallop design that permits dual pressure service (150/300 lb). These sizes fit properly between any Cast Iron ANSI Class 125/250 or Ductile Iron ANSI Class 150/300 flanges. Sizes 8" through 12" are only rated for ANSI Class 150 service. The bolting pattern for Cast Iron Class 125/250 and Ductile Iron Class 150/300 are the same, respectively.

Ductile Iron check valves offer higher pressure ratings than Cast Iron check valves. For example, Ductile Iron check valves (2" ~ 24") are rated at 640 psi wog where as Cast Iron check valves (2" ~ 12") are rated at 500 psi wog and (14" ~ 24") are only rated at 300 psi wog.

**DIMENSIONS AND PERFORMANCE DATA (1)**

SIZE	in	2	2 1/2	3	4	5	6	8	10	12 (2)
	mm	50	65	80	100	125	150	200	250	300
<b>A DIMENSION</b> FACETO FACE	in	2.62	2.87	3.12	4.0	4.62	5.62	6.50	8.25	11.25
	mm	67	73	79	102	117	143	165	210	286
<b>ØB DIMENSION</b> SCALLOP DIAMETER 150 lb (2" THROUGH 12")	in	4.0	4.75	5.25	6.75	7.62	8.62	10.87	13.25	n/a
	mm	102	121	133	171	194	219	276	337	n/a
<b>ØC DIMENSION</b> OUTSIDE DIAMETER 300 lb (2" THROUGH 6")	in	4.25	5.0	5.75	7.0	8.37	9.75	n/a	n/a	n/a
	mm	108	127	146	178	213	248	n/a	n/a	n/a
<b>ASSEMBLED WEIGHT</b>	lb	4.5	7.0	9.5	17.5	25.5	38.0	88.0	162.0	300.5
	kg	2.0	3.2	4.3	7.9	11.6	17.2	39.9	73.4	136.2
<b>Flow Coefficient</b>	C <sub>v</sub>	60	95	150	230	310	450	750	1250	1800
<b>Cracking Pressure (3)</b>	psi	≤ .5	≤ .5	≤ .5	≤ .5	≤ .5	≤ .5	≤ .5	≤ .5	≤ .5

- Dimensions, weights, and flow coefficients are provided for reference only. When required, always request certified drawings.
- Size 12" is not scalloped, but tapping for cap screws is provided. Contact factory for diameter dimension if needed.
- Cracking pressure is for horizontal installations only. For vertical installations, please consult factory.

**PRESSURE-TEMPERATURE RATINGS (1)**

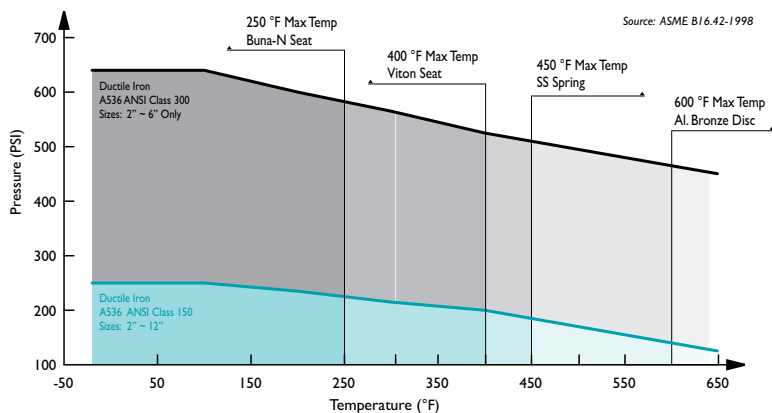

- This chart displays the pressure-temperature ratings for the valve's body per ASME B16.42-1998. Maximum temperature limits have been added for seat and spring materials.

**ORDERING CODE**

Model Number	Description
CV90-DI-B-1	Ductile Iron Body, Bronze Seat and Disc, Buna-N Seat
CV90-DI-S-3	Ductile Iron Body, Stainless Steel Seat and Disc, Viton Seat

**REFERENCED STANDARDS & CODES**

CODE	DESCRIPTION
ANSI B16.42	Ductile Iron Pipe Flanges and Flanged Fittings
ANSI B16.5	Pipe Flanges and Flanged Fittings
MSS SP-6	Standards Finishes for Connecting-end Flanges
MSS SP-25	Standard Marking System for Valves
MSS SP-125	D.I., In-Line, Spring Loaded, Center-Guided Valves

**PRESSURE/TEMPERATURE RATING (1)**

ANSI Class	150 lb Service 2" ~ 12"	300 lb Service 2" ~ 6" only
WOG (Non-shock)	250 PSI @ 100 °F	640 PSI @ 100 °F

**SEAT AND SPRING TEMPERATURE RATINGS (1)**

SEAT (O-Ring)	Temperature Range
Buna-N	-20 °F @ 250 °F
Viton	-40 ~ 400 °F
SPRING	Maximum Temperature
Stainless Steel	450 °F

- The listed pressure and temperature ratings for the valve's body, seat, and spring are theoretical and may vary during actual operating conditions.

Titan FCI makes every effort to ensure the information presented on our literature accurately reflects exact product specifications. However, as product changes occur, there may be short-term differences between actual product specifications and the information contained within our literature. Titan FCI reserves the right to make design and specification changes to improve our products without prior notification. When required, request certified drawings.