



TITAN FLOW CONTROL, INC.

SILENT CHECK VALVE ♦ WAFER TYPE ♦ CENTER GUIDED

ANSI CLASS 150/300 ♦ STAINLESS STEEL BODY

MODEL: CV 91-SS

Body: Stainless Steel
Trim : Stainless Steel
Seats: Stainless Steel
Size Range: 2" ~ 12"



Sizes 2" ~ 6" provide
Dual Pressure Service
ANSI Class 150/300

FEATURES

- ◇ **DESIGNED FOR LONG SERVICE LIFE**
THE CV 91'S STAINLESS STEEL BODY AND TRIM ARE HIGHLY CORROSION RESISTANT, EXTREMELY STRONG, AND WELL SUITED FOR HIGH TEMPERATURE APPLICATIONS - UP TO 1000°F IN CONTINUOUS SERVICE. DUCTILE IRON BODIES ARE ALSO AVAILABLE FOR LOWER TEMPERATURE APPLICATIONS.
- ◇ **MINIMAL HEAD LOSS**
HEAD LOSS IS MINIMIZED BY PROVIDING A LARGE CROSS-SECTIONAL AREA WHICH EXCEEDS THAT OF THE ADJACENT PIPELINE. ADDITIONALLY, THE SPRING-LOADED, CENTER GUIDED DISC IS DESIGNED WITH VERY LOW CRACKING PRESSURE WHICH REDUCES THE AMOUNT OF ENERGY REQUIRED TO OPEN THE VALVE.
- ◇ **QUICK CLOSURE TO REDUCE WATER HAMMER**
SILENT SHUT-OFF IS ACHIEVED VIA THE FULLY AUTOMATIC, SPRING ASSISTED DISC THAT CLOSES NEAR ZERO FLOW VELOCITY. THE LIGHTWEIGHT, CENTER GUIDED DISC DESIGN CREATES A POSITIVE SHUTOFF PRIOR TO FLOW REVERSAL AND HELPS TO KEEP SLAMMING AND SURGES TO A MINIMUM.
- ◇ **METAL-TO-METAL SEATS**
PRECISION MACHINED SEALING SURFACES ALLOW THE CV 91-SS TO MAINTAIN A TIGHT SEAL THAT MEETS OR EXCEEDS API 598 LEAKAGE REQUIREMENTS. RESILIENT SEATS CAN ALSO BE FURNISHED. PLEASE CONTACT FACTORY.
- ◇ **VERSATILE DESIGN**
SIZES 2" THROUGH 6" UTILIZE A UNIQUE SCALLOP DESIGN THAT PERMITS DUAL PRESSURE SERVICE (ANSI CLASS 150 AND 300). SIZES 8" THROUGH 12" ARE ONLY RATED FOR ANSI CLASS 150.

TECHNICAL

PRESSURE/TEMPERATURE RATING ⁽¹⁾ STAINLESS STEEL - ASTM A351 Gr. CF8M- CLASS 150
WOG (Non-shock): 275 PSI @ 100 °F (2" ~ 12")
PRESSURE/TEMPERATURE RATING ⁽¹⁾ STAINLESS STEEL - ASTM A351 Gr. CF8M- CLASS 300
WOG (Non-shock): 720 PSI @ 100 °F (2" ~ 6")
SEAT MATERIAL ⁽¹⁾ TEMPERATURE RANGE
STAINLESS STEEL: -325 ~ 1500 °F
SPRING MATERIAL ⁽¹⁾ MAXIMUM TEMPERATURE
STAINLESS STEEL: 450 °F

1. The above listed temperatures are theoretical and may vary during actual operating conditions.

APPLICATIONS

MARKETS: OIL AND GAS PRODUCTION, GENERAL INDUSTRY, CHEMICAL, PETROCHEMICAL, POWER, FOOD AND BEVERAGE

SERVICE: PUMP DISCHARGE SERVICE IN MUNICIPAL WATER, IRRIGATION, AND INDUSTRIAL CLASS HVAC SYSTEMS. IT IS RECOMMENDED THAT A TITAN FCI STRAINER BE INSTALLED AHEAD OF THE PUMP TO ENSURE PROTECTION OF THE CHECK VALVE AND THE PUMP.

PRECAUTIONS: THIS VALVE IS INTENDED FOR LIQUID SERVICE THAT DOES NOT EXCEED 10 FT/SEC. IT IS DESIGNED FOR STEADY FLOW CONDITIONS AND IS NOT RECOMMENDED FOR USE IN RECIPROCATING PUMP, COMPRESSOR OR OTHER TYPE OF PHYSICAL/THERMAL SHOCK-LOAD APPLICATIONS. THIS VALVE IS NOT RECOMMENDED FOR STEAM SERVICE OR FLOW MEDIA THAT CONTAINS SOLIDS. IT SHOULD BE INSTALLED AT LEAST FIVE PIPE DIAMETERS DOWNSTREAM FROM ANY TURBULENCE PRODUCING COMPONENTS. FLOW STRAIGHTENERS MAY BE REQUIRED IN CERTAIN APPLICATIONS.

The above data represents common market and service applications. No representation or guarantee, expressed or implied, is given due to the numerous variations of concentrations, temperatures and flow conditions that may occur during actual service.

TITAN FLOW CONTROL, INC.

YOUR PIPELINE TO THE FUTURE!

Tel: 910-735-0000 ♦ Fax: 910-738-3848 ♦ titan@titanfci.com ♦ www.titanfci.com
290 Corporate Drive ♦ PO Box 7408 ♦ Lumberton, NC 28358



TITAN FLOW CONTROL, Inc.
 290 Corporate Drive
 Lumberton, NC 28358
 Tel: 910.735.0000
 E-mail: titan@titanfci.com
 Web: www.titanfci.com
 Fax: 910.738.3848

SILENT CHECK VALVE • WAFER TYPE
CENTER GUIDED DESIGN • STAINLESS STEEL
MODEL: CV 91-SS - Stainless Steel Body

ANSI
Class
150/300

BILL OF MATERIALS (1)

No.	PART	CV 91-SS-S
1	Body (2)	A351 Gr. CF8M Type 316
2	Seat (3) (4)	A351 Gr. CF8M Type 316
3	Disc	A351 Gr. CF8M Type 316
4	Spring (4)	Series 300 Stainless Steel
5	Bushing (4)	A351 Gr. CF8M Type 316
6	Screws (4)	ASTM A276 Type 304 Stainless Steel

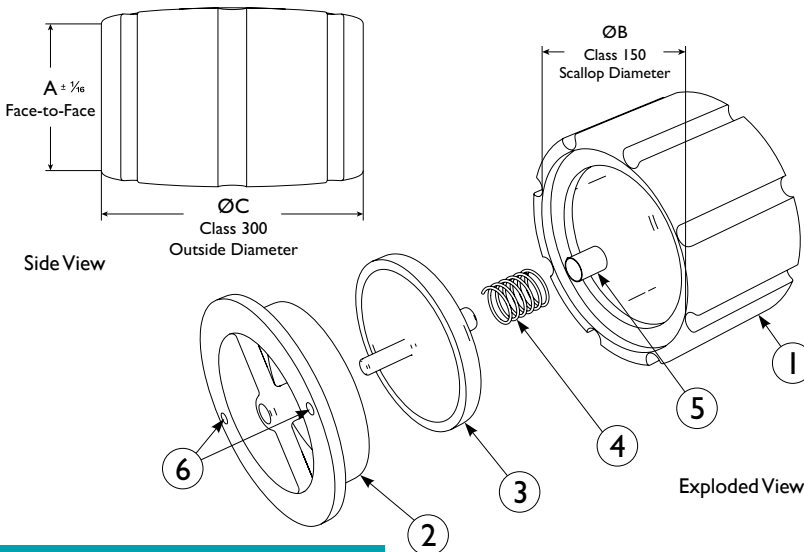

1. Bill of Materials represents standard materials. Equivalent or better materials may be substituted at the manufacturer's discretion.
2. Ductile Iron Bodies (CV90 Series) are also available.
3. Resilient, soft seats also available — Please consult factory.
4. Denotes recommended spare parts.

DIMENSIONS AND PERFORMANCE DATA (1)

SIZE	in	2	2 1/2	3	4	5	6	8	10 (2)	12 (2)
	mm	50	65	80	100	125	150	200	250	300
A DIMENSION FACE TO FACE	in	2.625	2.875	3.125	4.0	4.625	5.625	6.50	8.25	11.25
	mm	67	73	79	102	117	143	165	210	286
ØB DIMENSION SCALLOP DIAMETER 150 lb (2" THROUGH 12")	in	4.125	4.75	5.25	6.75	7.625	8.625	10.875	n/a	n/a
	mm	105	121	133	171	194	219	276	n/a	n/a
ØC DIMENSION OUTSIDE DIAMETER 300 lb (2" THROUGH 6")	in	4.25	5.0	5.75	7.0	8.375	9.75	n/a	n/a	n/a
	mm	108	127	146	178	213	248	n/a	n/a	n/a
ASSEMBLED WEIGHT	lb	4.5	6.5	8.5	16.0	25.0	37.5	70.0	140.0	324.0
	kg	2.0	2.9	3.9	7.2	11.3	17.0	31.8	63.5	146.8
Flow Coefficient	C _v	60	95	150	230	310	450	750	1250	1800
Cracking Pressure (3)	psi	≤ .5	≤ .5	≤ .5	≤ .5	≤ .5	≤ .5	≤ .5	≤ .5	≤ .5

Additional Design & Technical Notes:

Sizes 2" through 6" utilize a unique scallop design that permits dual pressure service (150/300). These sizes fit properly between any ANSI Class 125/250 or ANSI Class 150/300 flanges. Sizes 8" through 12" are only rated for ANSI Class 150 service. The bolting pattern for ANSI Class 125/250 and ANSI Class 150/300 are the same, respectively.

Valves are for liquid service only. They should be installed at least five pipe diameters downstream from any turbulence producing components.

Resilient soft seats are also available. Please contact factory for price and delivery.

1. Dimensions, weights, and flow coefficients are provided for reference only. When required, always request certified drawings.
2. Sizes 10" and 12" are not scalloped, but tapping for cap screws is provided. Contact factory for diameter dimension if needed.
3. Cracking pressure is for horizontal installations only. For vertical installations, please consult factory.

PRESSURE-TEMPERATURE RATINGS (1)

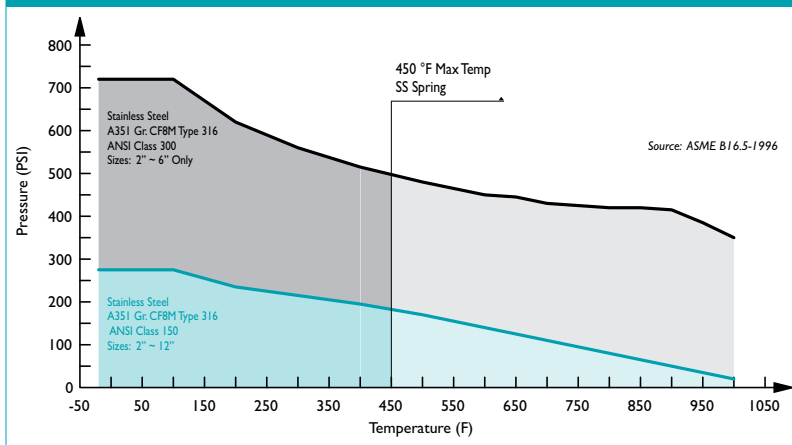

1. This chart displays the pressure-temperature ratings for the valve's body per ASME B16.5-1996. Maximum temperature limits have been added for seat and spring materials.

ORDERING CODE

Model Number	Description
CV91-SS-S	Stainless Steel Body, Stainless Steel Seat, Disc, and Seat

REFERENCED STANDARDS & CODES

CODE	DESCRIPTION
ANSI B16.5	Pipe Flanges and Flanged Fittings
MSS SP-6	Standards Finishes for Connecting-end Flanges
MSS SP-25	Standard Marking System for Valves
MSS SP-55	Quality Standard for Valve Castings
MSS SP-126	Steel, In-Line, Spring-Assisted, Center-Guided Valves

PRESSURE/TEMPERATURE RATING (1)

ANSI Class	150 lb Service 2" ~ 12"	300 lb Service 2" ~ 6" only
WOG (Non-shock)	275 PSI @ 100 °F	720 PSI @ 100 °F

SEAT AND SPRING TEMPERATURE RATINGS (1)

SEAT	Temperature Range
Metal	-325 °F @ 1500 °F
SPRING	Maximum Temperature
Stainless Steel	450 °F

1. The listed pressure and temperature ratings for the valve's body, seat, and spring are theoretical and may vary during actual operating conditions.

Titan FCI makes every effort to ensure the information presented on our literature accurately reflects exact product specifications. However, as product changes occur, there may be short-term differences between actual product specifications and the information contained within our literature. Titan FCI reserves the right to make design and specification changes to improve our products without prior notification. When required, request certified drawings.