

Strainer Introduction - Design Features

DEFINITION: A pipeline strainer is a device which, when installed in a pipeline, provides a means of mechanically removing solids from a flowing fluid or gas by utilizing a perforated or mesh strainer element.

Strainers are generally employed in pipelines to protect any piece of mechanical equipment such as: Control Valves, Pressure and Temperature Regulators, Condensers, Heat Exchangers, Pumps, Steam Traps, Meters, Spray Nozzles, etc. from damaging grit, dirt, scale and other foreign matter. "Y" and Basket Strainers take their name from their configuration. Basket Strainers tend to be larger in size with an open area that is actually many times greater than pipe size. They are intended for applications where small amounts of solid particulate are expected and where clean out will be infrequent. For applications where continuous operation is required and where the line cannot be shut down for clean out, Duplex, twin Basket Strainers or Automatic Designs can be used.

If solids will flush easily from the screen and fluid can be exhausted to the atmosphere, a blow-off valve on the drain port will allow clean-out without removal of the screen and without interrupting the process flow. An extremely important consideration in the selection of a strainer is the size of the perforations or mesh used in the making of the screen. An additional concern is pressure drop. Since strainers can have a variety of fluids passing through them, pressure drop across the screen can increase very rapidly, cleaning will be essential in any strainer installation.

Basket Strainers tend to be larger in size and the open area is actually many times greater than pipe size.

Backflushing/Backwashing

In most applications, strainers can be easily adapted to back-flush giving results that are positive.

In many systems, particularly where solids are heavy and well defined, dirt accumulates as shown. When the backflush valve is open the differential that results between operating pressure and the backflush system removes the dirt, all without shutting the system down. This simple process is referred to as **Backflushing**.

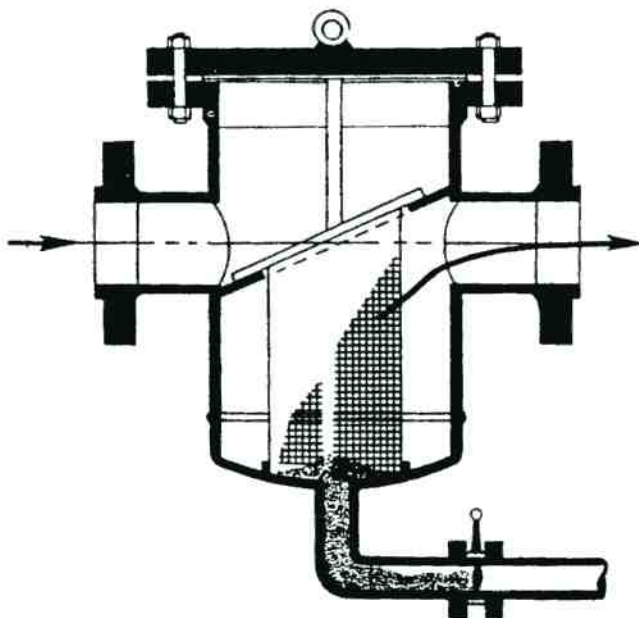

Titan's strainer product installations range from utility to severe applications. We service a wide variety of industries including; chemical, petro-chemical, refining, pulp and paper, marine, HVAC and many others.

TITAN DESIGN - ADVANTAGES

DESIGN STANDARDS - Body and shell material comply with ASME and ASTM materials standards for chemistry and strength. Wall thickness of body and other pressure containing components meet ASME B16.34.

FLANGED BODY cover joints are designed to meet full requirements of ASME section VIII, Div 1 And/or AMSE 16.5.

COVER DESIGN - Titan standard cover joints are machined to have a recess area designed to keep gaskets contained to prevent gasket failure. The gasket cavity is fully enclosed, ensuring proper gasket alignment, while preventing unwinding of spiral wound gaskets or extrusion of other softer materials such as Teflon, buna, graphoil, and many others. This also allows the cover to be easily guided to its exact position during assembly. It is also helpful when handling heavy covers as they tend to be difficult to maneuver.

THREADED BODY - This high end design feature is also standard in our threaded cap joints where much attention is paid to thread shear, cap thickness and seating loads.

WYE STRAINER CUT-AWAY VIEWS

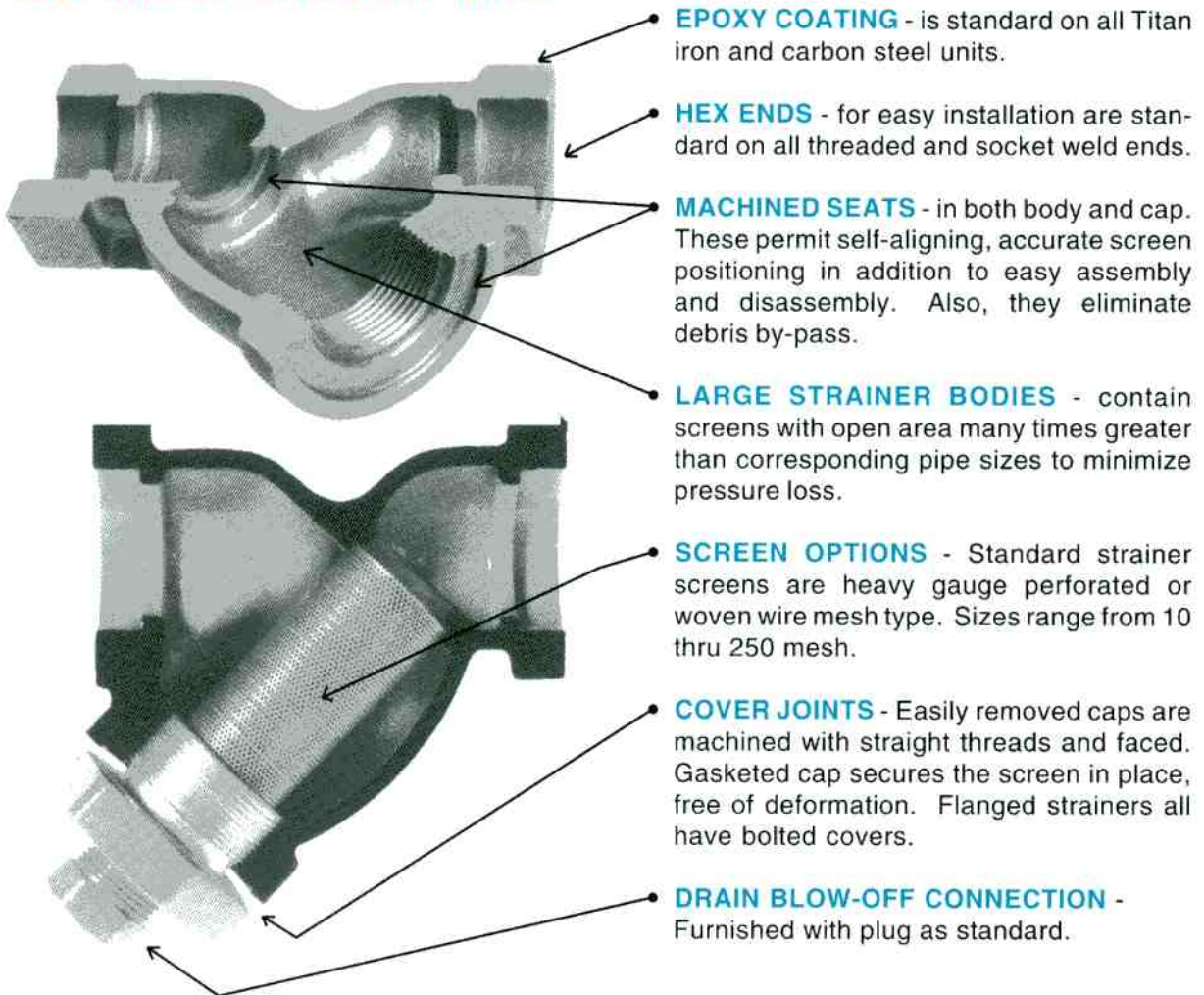

TITAN FLOW CONTROL PRODUCTS ARE DESIGNED WITH FEATURES AND BENEFITS THAT PROVIDE REAL VALUE